

INSTRUCTION MANUAL

for the

TYPE 086A MODEL P

SEMI - AUTOMATIC

BAG CLOSER & PRINTER

TYPE	MODEL	SERIAL NO.
<input type="text"/>	<input type="text"/>	<input type="text"/>



Kwik Lok[®] CORPORATION

EXECUTIVE OFFICE P.O. BOX 9548 YAKIMA, WA. 98909

TELEPHONE: 1-800-688-5945 or (509) 248-4770

FAX: (509) 457-6531

Internet: www.kwiklok.com

TYPE086A MODEL P CLOSER

TABLE OF CONTENTS

SECTION	HEADING	PAGE
I	SPECIFICATIONS.....	1.1 - 1.2
II	OPERATION.....	2.1 - 2.3
III	ADJUSTMENTS.....	3.1 - 3.13
IV	TROUBLESHOOTING.....	4.1 - 4.5
V	PARTS IDENTIFICATION.....	5.1 - 5.11
VI	WIRING.....	6.1
	APPENDIX.....	A - F

GENERAL SAFETY INFORMATION

Be sure the following safety instructions are read, understood and become a part of daily practice when operating or maintaining the closer.

1. Do not attempt to operate the closer until you understand its function. Study the manual carefully.
2. Keep all foreign material away from the drive system.
3. Keep fingers out of the closer and printer and away from any moving parts.
4. The printer cover must be in the closed position before applying power to and operating the closer / printer. Electrical power should be disconnected from the closer while the printer cover is open.
5. Disconnect the power cord before making any adjustments or maintenance. Moving the switch to the "STOP" position does not remove power from many electrical components, nor does it disable the motor. All adjustments, except as noted, are to be made with power disconnected.
6. The closer is normally operated from a counter or table. While the closer is very stable when operated from a flat a solid surface, care should be taken not use it in a way that could cause it to tip or fall from the operating surface.



THE TYPE 086A MODEL P MACHINE SEMI-AUTOMATICALLY CLOSES PLASTIC BAGS WITH THE STRIPLOK® CLOSURE AND CLOSURE LABEL.

A. The closing machine designated Type 086A:
Model 200P uses RL and SL series closures.
Model 300P uses L series closure labels.
Model 400P uses U series closure labels.
Model 500P uses CR series closure labels.

B. The system will close a wide range of product size variations. The Striplok closures are available in many closure opening sizes to accommodate a large number of variations in bag width and film material thickness.

Upon request and upon receipt of sample bags, the factory will gladly recommend the proper closure opening sizes. Use the bag length formula found in the appendix of this manual to help determine the proper bag length needed.

C. A suggested spare parts inventory is listed in the appendix. To save valuable time, it is recommended that an adequate supply of these parts be kept on hand for needed repairs.

SECTION I

Specifications

086A MODEL P SEMI-AUTOMATIC BAG CLOSING MACHINE SPECIFICATIONS

TYPE	MODEL	CLOSURE	SPEED
086A	200P	RL and SL (or R and S unprinted)	Up to 30 Bags/Min.
	300P	L Labels (medium and heavy duty)	
	400P	U Labels (medium and heavy duty)	
	500P	CR Labels (medium and heavy duty)	

The following is a description of available printer kits, descriptions and their respective Kwik Lok Kit numbers.

PRINTER KIT NUMBER	MODEL	PRINTER TYPE (DESCRIPTION)
Z0086017	PB	Band printer - Non European
Z0086018	PC	Band printer - European
Z0086019	PD	Block printer - Non European
Z0086020	PE	Block printer - European

1. The 086A Model P prints on closures or closure labels as defined in the chart above. It uses a type band printhead or a block with grooved rubber type. Contact your distributor or Kwik Lok Corporation for printing supplies.
2. The 086A Model P semiautomatic closer comes standard with mounted rubber feet. Optional suction cup feet are available.
3. The 086A Model P is available for use with the following electrical power:

115VAC, 60 Hz, 1 amp, single phase
220 - 240VAC, 50 Hz, 0.38 amp, single phase

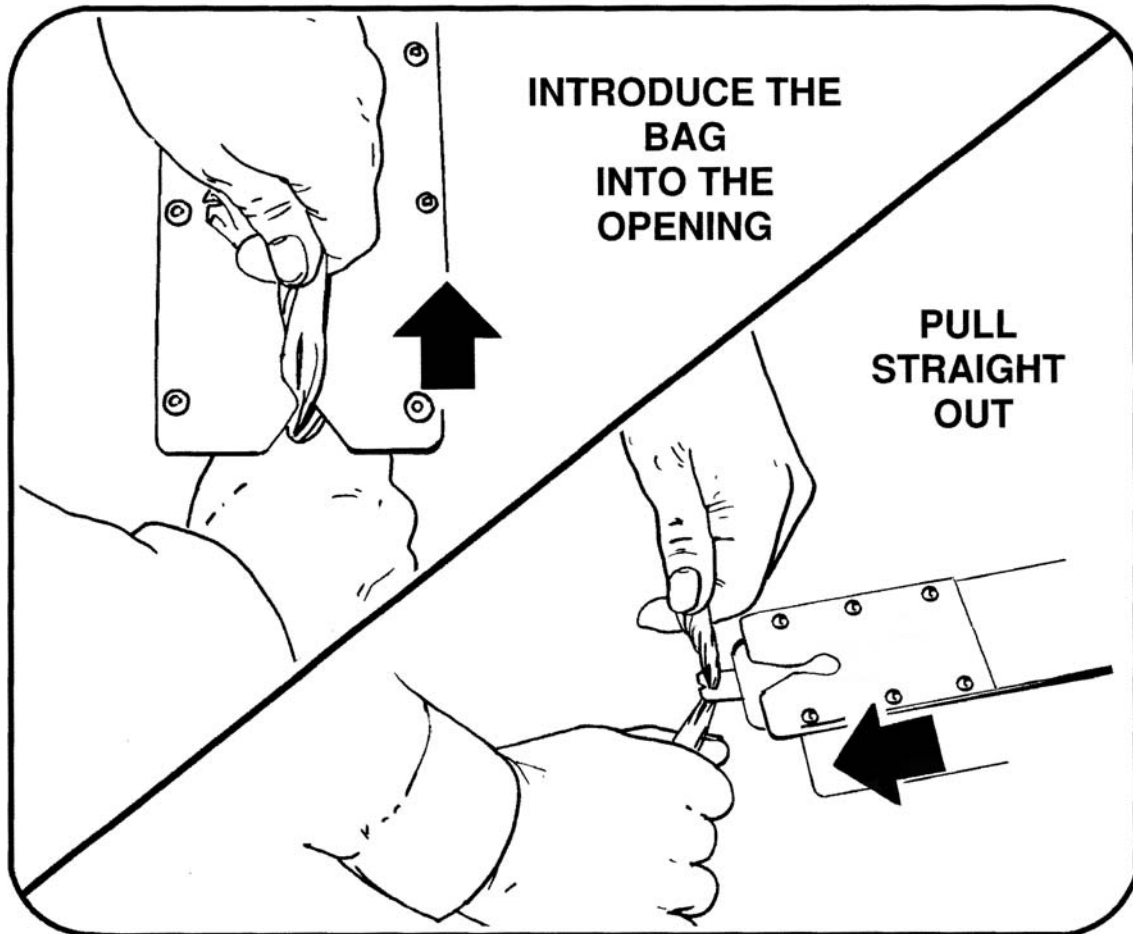

Figure 2.1

A. OPERATING SEQUENCE:

The closer is ready to run when a closure is in the closing position, the switch is in the "RUN" position and the "READY" light is on.

THE PRINTER COVER MUST ALWAYS BE IN THE CLOSED POSITION WHEN OPERATING THE CLOSER.

1. Plug in the closer.
2. Install a roll of closures and feed the strip into the closure track. See part B in this section.
3. Flip the switch to the "RUN" position. A closure will move into the closing position if one is not already there, and the "READY" light will come on.
4. Close the bag and remove it from the closer. See part E in this section.
5. The closer cycles to print a closure and position a new closure into the closing position ready for the next bag, while the "READY" light goes off momentarily.
6. If no closure is available to move into the closing position, the machine will cycle and the "READY" light will go on and off repeatedly until the switch is moved to the "STOP" position.

SECTION II

Operation

B. LOADING A ROLL OF CLOSURES:

1. Cycle the closer until the closures stop advancing. (Avoid cycling the closer more than necessary when there is no closure in the closing position. This will avoid a buildup of ink residue on the closure track).
2. Move the switch to "STOP" so the mechanism is properly positioned. Never stop the machine by disconnecting the power.
3. Insert the closure hub into a new roll of closures.

When closing with labels, insert the closure hub so that the label of the closure will be right side up when the closure strip is in the closure track.

4. Install the hub and roll. Be certain the closures feed forward from the bottom of the roll.
5. Open the printer cover and check to see if there is any ink residue on the bottom of the closure track within the printing area. Use a soft cloth or tissue to wipe any ink off the closure track so the ink will not smear on the underside of the closure.
6. Remove the masking tape and feed the end of the strip into the closure track until the first closure has passed the check and is against the stop. Close the printer cover.
7. Move the switch to the "RUN" position. The closer will cycle once and move a closure into the closing position. Remove the first three unprinted closures by hand. The closer is now ready to close bags.

C. PREPARING THE PRINTER:

1. Open the printer cover.
2. Select the print image.
 - a. For the band printer, rotate the top of the print-head toward the front of the closer so the selected type characters can be easily viewed through the window on the top of the print head. Slide the selector knob out to select the desired band and rotate the knob to select the desired character. When finished rotate the bandhead back against the spacer (item 7, Figure 5.3).
 - b. For the typeholder block, remove the locking knob (item 14, Figure 5.4) and slide the printer block off the shaft and spring pin. Place the selected type in the grooves that are the farthest away from the holes in the mounting block. For normal viewing on the closure the bottom edge of the characters should be toward the middle of the block. Center the type from side to side. Replace the block on the shaft and pin so the type is close to the ink roll arm. If the type or typeholder block is not installed correctly, the type will not be inked properly.
3. Unscrew the ink roll knob and position the ink roll between the knob and the cam follower (item 3, Figure 5.3).
4. Mate the ink roll to the end of the cam follower and screw in the knob to secure it. Under most conditions the ink roll can be left on the printer until the ink is used up. The ink roll will not dry out.
5. Close the printer cover.
6. Cycle the printer and discard the unprinted closures.

D. ADJUSTING THE PRINT FORCE:

DO NOT USE EXCESSIVE PRINT FORCE TO COMPENSATE FOR PRINTING IMPERFECTIONS.

The operator can adjust the print force.

Always operate the printer with the minimum print force that will produce acceptable printing. A quarter turn of the knob is a large adjustment. If a significant change in print quality is not noticed, return to the previous setting and refer to Section III Adjustments and Section IV Trouble Shooting to correct any problems.

When the ink roll will no longer adequately ink the type, replace it. Do not attempt to extend the life of the ink roll by increasing the printing force.

To increase the print force, turn the knob (item 23, Figure 5.3 or item 19, Figure 5.4) counterclockwise. If the effort to turn the knob suddenly decreases, the maximum print force has been reached.

To decrease the print force, turn the knob clockwise.

E. CLOSING BAGS: (Figure 2.1)

1. Grasp the bag as shown. Spin the bag to twist the bag neck. Twisting the bag helps the material to enter the closure smoothly.
2. The lower hand should form a "V" to trap all of the bag material. This helps to completely insert the bag material into the closure opening.
3. Do not jam the bag material straight into the closure opening. The top hand should lead the bottom hand. Follow up with the lower hand until all of the bag neck is in the closure. A tight package is accomplished by holding the contents of the bag snugly up against the underside of the closure track.
4. Remove the closed bag with a horizontal motion.

SECTION III Adjustments

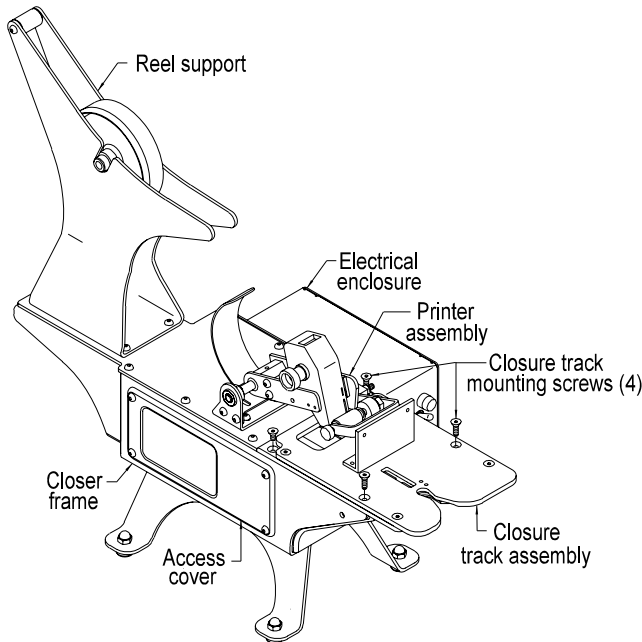

Figure 3.1

THE FOLLOWING ADJUSTMENTS ARE TO BE PERFORMED WITH THE CLOSER ELECTRICAL POWER DISCONNECTED AT THE PLUG-IN.

A. CLOSURE TRACK ASSEMBLY REMOVAL:

Some of the adjustments described in this section require removal of the closure track assembly.

1. Remove the side access cover (Figure 3.1).
2. Disconnect the two gold colored closure stop springs (OS-012) from the lower spring anchor screw (Figure 3.2). When the springs are reattached be careful not to stretch them.
3. Disconnect the silver colored spring (OS-006) from the ink roll arm (items 2, and 20, Figure 5.3).

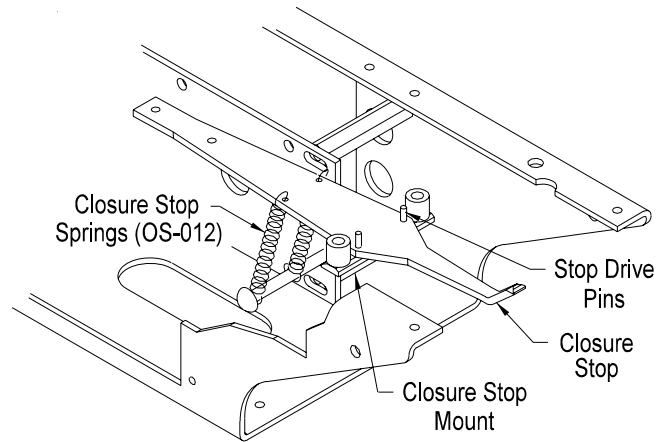

Figure 3.2

4. Disconnect the printer link (item 5, Figure 5.5) from the printer assembly at the pivot mount (item 35, Figure 5.4)
5. Remove the four flat head mounting screws which attach the closure track assembly to the closer main frame. Note that the closure track assembly can be removed from the closer with out removing the ink roll assembly or the printer cover from the closure track.

When remounting the track assembly, tighten the four mounting screws evenly.

6. Lift the closure track assembly slightly and depress the tip of the pick to disengage it from the closure track.
7. Raise the closure track assembly slightly off the frame and disconnect the two wire leads from the sensor lever limit switch.

To remount the closure track assembly, reverse the above procedure. Before closing the access cover, check to see that there are no pinched wires or wires routed close to moving parts.

SECTION III Adjustments

B. TOP CLOSURE TRACK REMOVAL:

The top of the closure track can be removed from the closer while the closure track assembly remains attached to the closer mainframe. This can be done to expose the slot that the closures move through. The closure track can be inspected and cleaned if needed (Figure 3.1).

1. Disconnect the 0S-006 spring (silver colored) from the ink roll arm (items 2 & 20, Figure 5.3)
2. Remove the front six flat head screws from the track top. Note the different screw lengths upon removal
3. Remove the top of the closure track from the rest of the lok track assembly.

C. CHECK POSITION:

The check stops the closure strip from moving backward while the pick retracts.

Refer to Figure 3.3 to further understand the check mounting position. For this adjustment the closure track must be removed from the closer.

For for these models, the check is mounted in the back mounting holes (farthest from the front of the closure track).

1. With the check mounted in the correct holes, and the mounting screws loose, slide the check forward toward the front of the closure track to the end of the mounting slots.
2. Tighten the mounting screws.

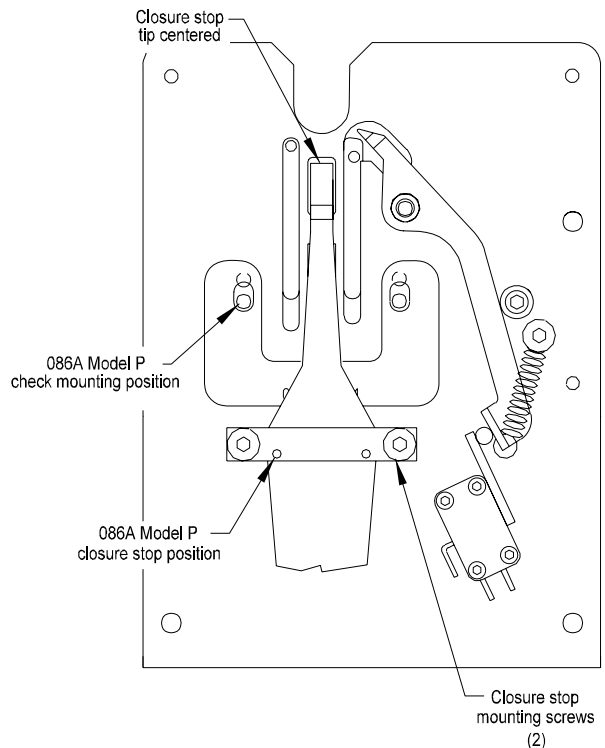

Figure 3.3
(Closure track assembly as viewed from the underside).

D. CLOSURE STOP POSITION:

The end closure is separated from the closure strip when the closure stop limits the travel of the second closure in the strip while the pick continues to advance the first closure.

As with the position of the check, the closure stop mount is located in a specific way depending on the closer model being adjusted.

1. The stop mount is mounted as shown (Figure 3.3).
2. Be sure the beveled edges of the mount are against the closure stop (Figure 3.4).

The closure stop tip must be centered in the slot located in the closure track for it.

SECTION III Adjustments

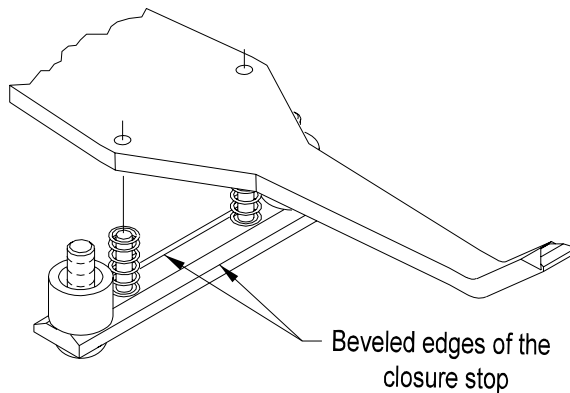

Figure 3.4

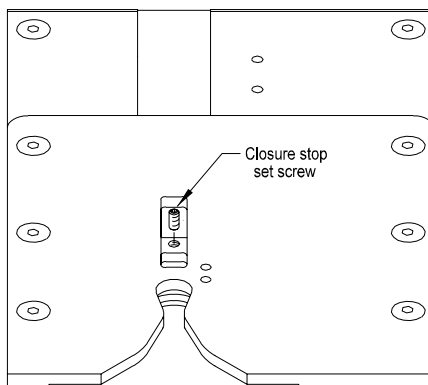

Figure 3.5

3. Slightly loosen the stop mount mounting screws.
4. Move the closure stop tip side to side until it is centered in the slot.
5. Tighten the mounting screws.
6. Turn the closure track assembly over so it is right side up in your hands. Again check the position of the closure stop tip as this is the way the closure track is oriented during operation. Readjust if needed.

E. CLOSURE STOP SETSCREW ADJUSTMENT:

When properly adjusted the closure stop set screw sets the height of the stop.

As the closure strip advances, the second closure in the strip is stopped. The leading closure continues to move forward and is then separated from the closure strip.

1. Remove any closures from the track.
2. Locate the top of the setscrew (Figure 3.5).
3. Turn the setscrew in or out to lower or raise the tip of the stop until it is 1/8" (3mm) below the top of the track top plate (Figure 3.6). If the tip of the stop will not raise as the setscrew is turned out, the stop may be bowed. If so the stop must be removed from the machine and the part straightened. Use thread locking compound to secure the setscrew.

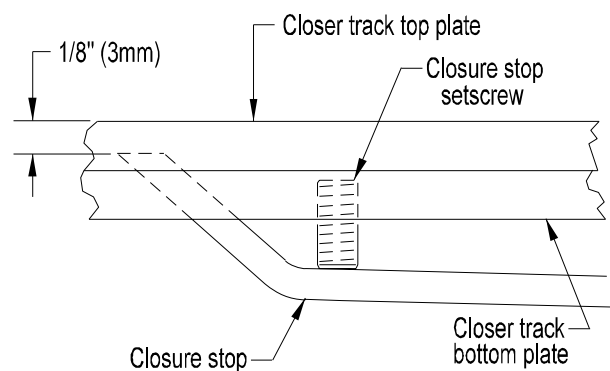

Figure 3.6

SECTION III Adjustments

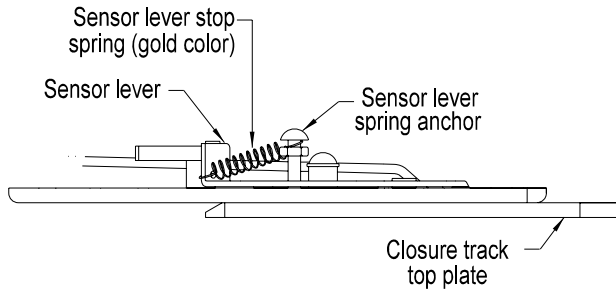

Figure 3.7

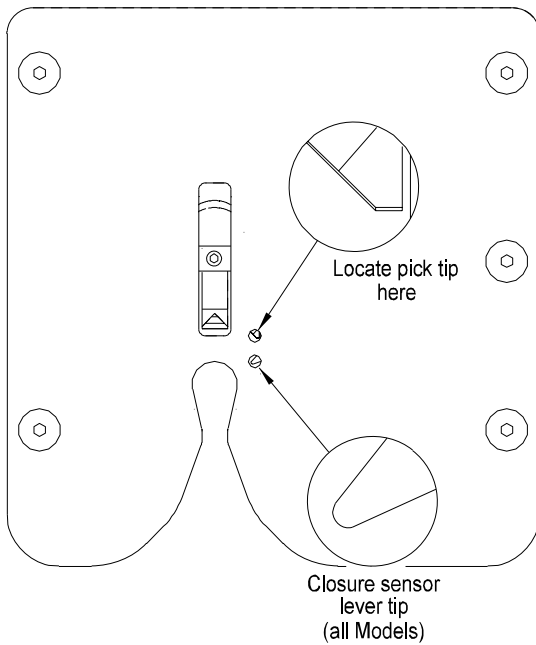

Figure 3.8

F. SENSOR LEVER SPRING:

The sensor lever spring is designed to apply force to the sensor lever tip against the side of the closure, as well as upward against the underside of the closure track. For the spring to operate correctly, it must be mounted as shown in Figure 3.7.

G. SENSOR LEVER STOP ADJUSTMENT: (Figures 3.8 & 3.9)

The sensor lever stop is a bushing which limits the travel of the sensor lever when no closures are present. The bushing is secured under a 10-32 buttonhead screw. There is clearance between the two, so the position of the bushing can vary. When no closures are present, the sensor lever tip should be centered below the inspection hole in the top track (Figure 3.8).

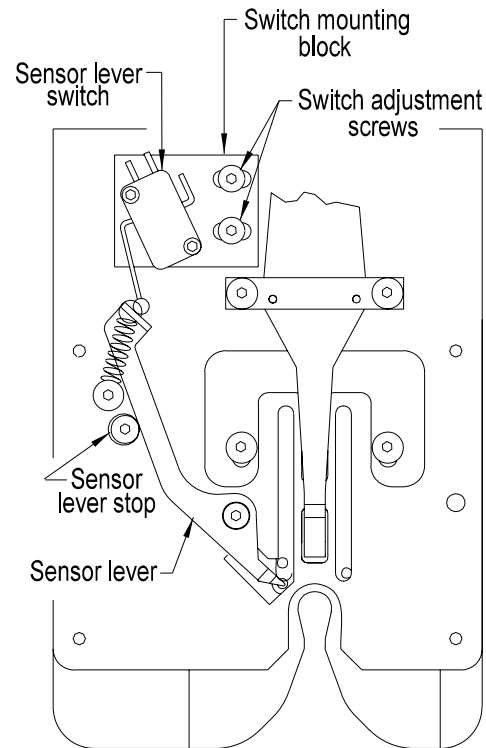

Figure 3.9

Closure track assembly as viewed from the underside.

SECTION III Adjustments

1. Loosen the mounting screw and move the bushing as needed.
2. Retighten the mounting screw.

H. SENSOR SWITCH ADJUSTMENT:

The sensor switch detects whether or not there is a closure in the closing position. When a closure moves into the closing position, the sensor switch stops the motor at the end of the cycle. When the closure is removed, the switch starts the motor. The switch should turn on and off midway between the positions of the sensor lever when it is resting against the sensor lever stop and when it is resting against the side of a closure.

1. Check to see if the sensor lever stop is adjusted correctly (part G above).
2. Turn the closure track upside down.
3. Feed a short strip of closures (4 or 5) through the track until the leading edge of the first closure just slides past the sensor lever then back out until the closure is free of the sensor lever. Continue to slide the strip back and forth while listening for an audible "click" indicating that the switch is turning on and off. If the strip of closures moves forward so far that it can't back up, push it out of the front of the track and start over. Adjust if needed as follows.
4. Slightly loosen the two button head screws in the switch mounting block (Figure 3.9).
5. Move the switch and mounting block toward or away from the sensor lever. Listen for an audible "click" of the switch as it turns on and off.
6. Tighten the mounting screws when the switch actuates as described above.

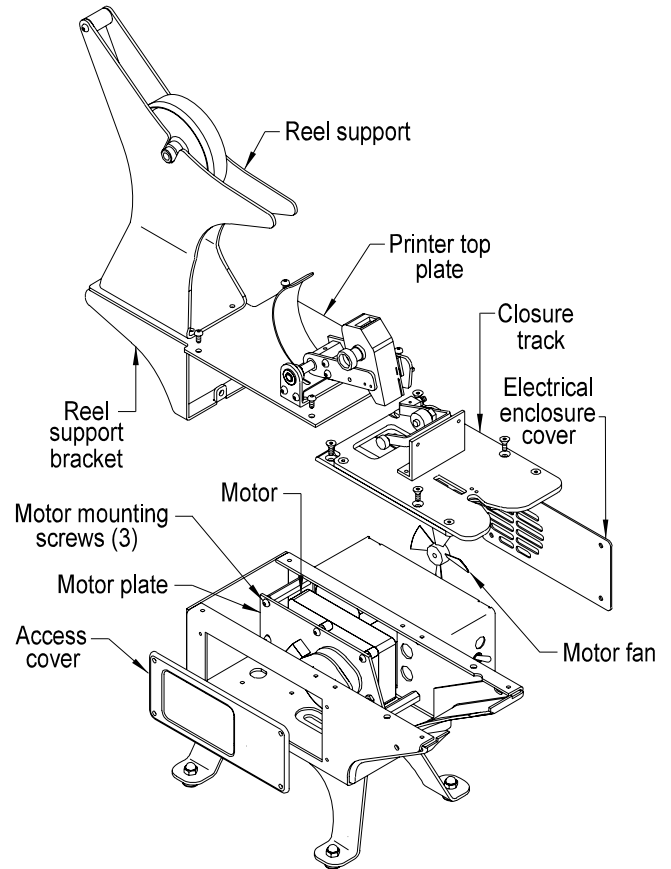

Figure 3.10

I. MOTOR REMOVAL: (Figure 3.10)

Anytime the three button head screws which are in the slots of the motor mounting plate are disturbed, the pick position must be checked. See part J this section.

The motor, motor mounting plate, cam assembly, cam switch block, printer cam arm and limit switch can be removed and reinstalled as an assembly. Component adjustment to this assembly can be made while the assembly is out of the frame of the closer. Remove the motor assembly as follows:

1. Disconnect power to the closer.

SECTION III Adjustments

2. Disconnect the 0S-006 spring (silver colored) from the ink roll arm.
3. Remove the pivot mount from the printer link.
4. Remove the screw connecting the reel support bracket to the back of the closer frame.
5. Remove the four mounting screws used to fasten the printer top plate to the closer main frame. Lift off the reel support bracket, reel support, top plate and printer mechanism from the mainframe.
6. Remove the side access cover.
7. Disconnect the pick spring (0S-117) from the pick. Remove the pick assembly from the closer cam.
8. Remove the electrical enclosure cover.
9. Carefully remove the fan from the motor shaft. Note the clamp on the inside of the fan. When the fan is reinstalled be sure to press the fan onto the motor shaft clamp side first. The end of the motor shaft should extend 1/16" to 1/8" (1.6mm-3.2mm) beyond the hub of the fan.
10. Disconnect the motor wires. Turn the toggle switch to expose one hard-to-reach motor lead.
11. Disconnect the cam switch electrical leads.
12. Remove the three mounting screws from the slotted holes in the motor mounting plate. Refer to part J this section for readjustment of the pick.
13. Remove the motor assembly through the top of the closer frame

14. To reinstall the motor assembly reverse these steps.

J. PICK / CLOSURE LOCATION:

The pick advances the closure strip and locates the leading closure in the bag closing position. To verify whether the pick stops in the correct position, check and adjust as follows:

1. Remove any closures from the closure track.
2. Verify that the pick is at the end of its travel. To do this plug in the closer. Turn the toggle switch to "RUN" and then to "STOP". The motor will stop with the cam and pick in their proper "parked" positions.

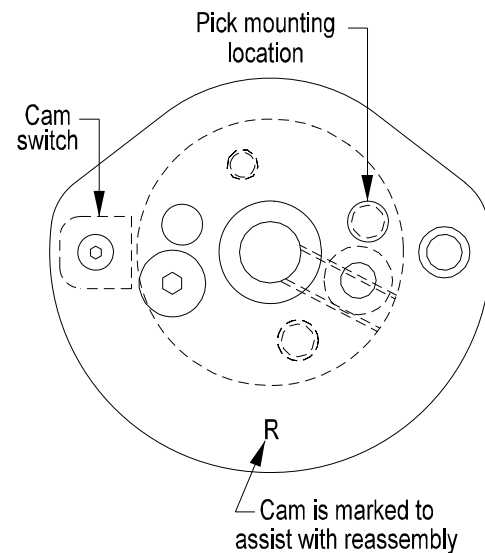

086A Model P

Figure 3.11

SECTION III Adjustments

3. With the motor stopped, disconnect the power cord.
4. The tip of the pick should be visible in half of the inspection hole as shown (Figure 3.8). Reposition the pick if needed as follows:

BE SURE THE POWER IS DISCONNECTED.

5. Remove the side access cover.
6. Loosen the three button head screws mounted in the slots at the corners of the motor mounting plate.
7. Slide the motor assembly until the pick is in the proper position when viewed through the inspection hole (Figure 3.8).
8. Tighten the mounting screws and again check the pick position. Reattach the access cover.

K. CAM ASSEMBLY:

The closer cam drives the pick through its cycle and raises the closure stop at the proper time to stop the closure strip so the leading closure can be separated from the remaining strip. The printer cam operates the printer mechanism. The closer cam and the printer cam fasten to either side of the cam hub. Additionally the switch cam contacts the cam switch which stops the motor and cam assembly when the pick is in the parked or neutral position (Figure 3.13). The cam assembly should remain on the motor shaft with no need for adjustment. If, however, the cam assembly is disassembled, the following information is helpful to reassemble it.

The two cams and hub can only be assembled correctly one way. It may be helpful to mark the cams to the hub prior to removing the cams from the hub.

The hub is designed with a shoulder on either side at the center. One shoulder is larger than the other.

1. Turn the hub so the small shoulder is face up. This is the printer cam side. Set the printer cam onto the hub with the countersunk hole in the printer cam facing up. Turn the cam on the hub until one of the two countersunk holes in the hub align with the countersunk hole of the printer cam.
2. Fasten the printer cam to the hub with one 8-32 x 3/8 flathead and one 1/4 -20 x 1/2 button head screw.

3. Turn the hub over so the printer cam is down.

Notice that the closer cam has an "R" stamped on one side (Figure 3.11)

4. Place the closer cam on the hub with the "R" face up. Turn the closer cam until the countersunk hole closest to the center of the cam aligns with the countersunk hole in the cam hub.

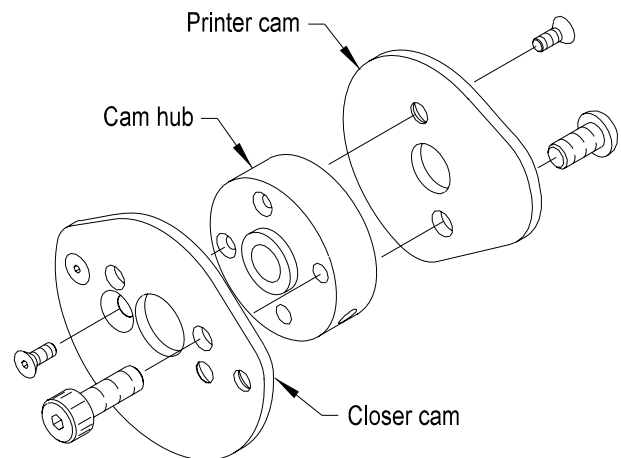

Figure 3.12

SECTION III Adjustments

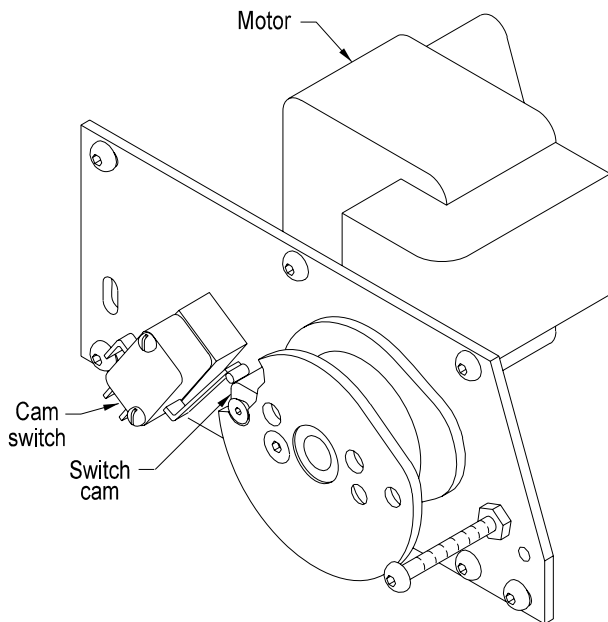

Figure 3.13

5. Fasten the closer cam to the hub with one 8-32 x 3/8 flat head. The second hole is to mount the closer pick after the cam assembly is remounted and fixed to the motor shaft.
6. If the switch cam (Figure 3.13) has been removed, remount it after the cam and hub have been connected. Square up the switch cam to the cam hub and then tighten into place.
7. Refer to part L below to adjust the lateral position of the cam assembly to the motor shaft.

L. CAM ASSEMBLY LATERAL ALIGNMENT:

1. Set the lateral (side to side) position of the cam assembly so the outside edge of the pick cam measures 15/16" (24mm) from the outside edge of the motor plate (Figure 3.14)

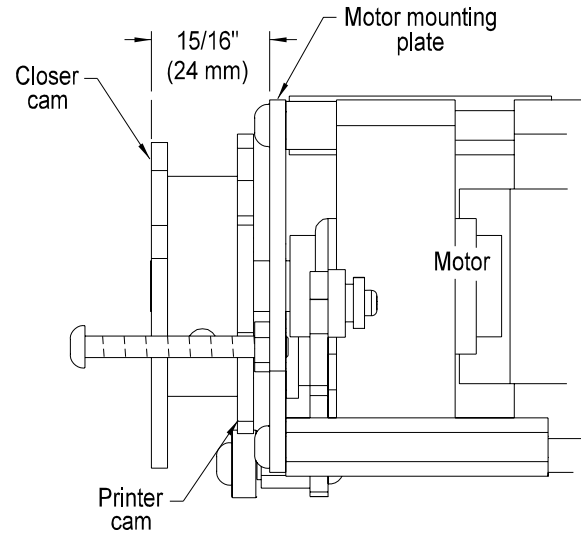

Figure 3.14

2. Rotate the cam assembly to position the set screw over the flat on the motor shaft and tighten the set screw. The angular position of the cam assembly is not important because the motor will stop with the cam in the correct position when the switch cam contacts the limit switch.
3. Tighten the set screw.

M. CAM SWITCH MOUNTING:

The cam switch allows the cam assembly to rotate and only stop when a closure reaches the bag closing position. The switch cam on the cam assembly (Figure 3.11& 3.13) actuates the switch. If the toggle switch is in the "RUN" position, the "READY" light will be on while the cam switch is actuated. The cam switch should not need adjustment.

SECTION III Adjustments

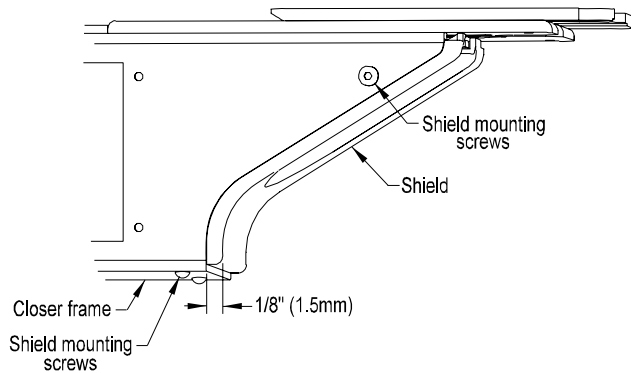

Figure 3.15

N. SHIELD POSITION:

There is no need to remove the shield when working on the closer. If however the shield requires remounting, refer to Figure 3.15 to determine the shield location. Repositioning the shield is done with the closure track assembly removed. Refer to part A this section.

O. PRINTHEAD LOCATION- SIDE TO SIDE: (Figure 3.16)

The printhead should be centered between the sides of the closure strip. If it is not, it will not align properly with the ink roll. The printhead can be manually pressed against the closure to determine where the image will be on the closure. The band printhead must be rotated back against the spacer at all times. To center the print head, loosen the set screw in the printer block lever and slide the printhead assembly along the printer shaft. When the set screw is tightened, it should bear against a flat on the printer shaft. The two set screws in the set collars and the set screw in the printer lever should be in line.

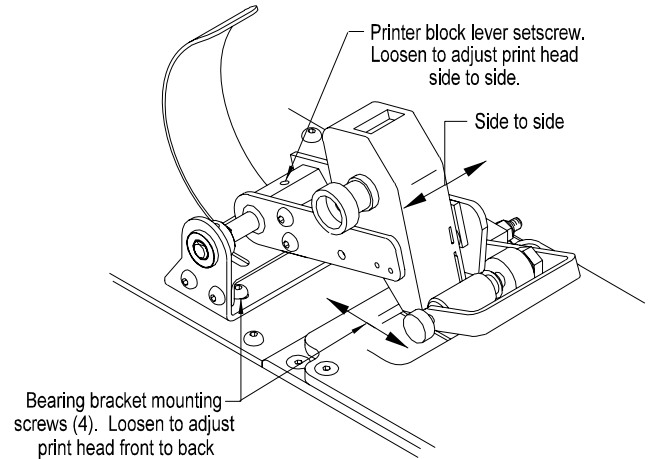

Figure 3.16

P. PRINTHEAD LOCATION- FRONT TO BACK: (Figure 3.16)

The printhead assembly can be moved backward or forward to locate the printed image on the closure. Before adjusting be sure the top of the bandhead is rotated back against the spacer (item 7, Figure 5.3)

1. Loosen the four button head screws that secure the bearing bracket to the top plate. Slide the assembly as needed. Use a square along the back edge of the bearing bracket and the side of the top plate. Whenever the printhead is moved, the ink roll arm mount will need to be

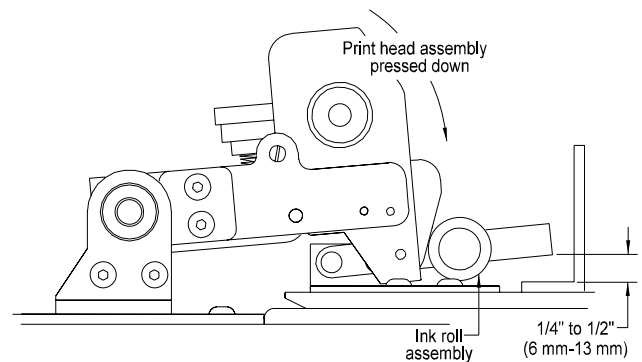

Figure 3.17

SECTION III Adjustments

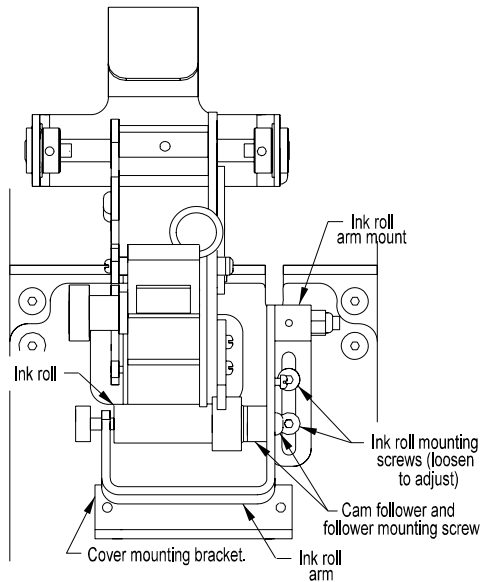

Figure 3.18

repositioned. If the printhead assembly is moved forward (toward the bag closing location), the ink roll arm mount may have to be moved out of the way first. Do not run the machine under power until the ink roll arm is repositioned properly. See part Q below.

Q. INK ROLL ARM POSITION: (Figure 3.14)

The ink roll arm must be positioned so that the mechanism does not bind and the type face is completely inked. Manually depress and release the ink roll arm to determine if it operates freely. Use only the silver 0S-006 spring (item 20, Figure 5.3). If needed, clean and oil the shaft of the ink roll arm.

When the printhead is manually depressed, the ink roll arm should clear the flange of the cover mount bracket by 1/4" to 1/2" (6mm to 13mm) (Figure 3.17).

1. To adjust loosen the two screws, which secure the ink roll mount arm to the top track (Figure 3.18).

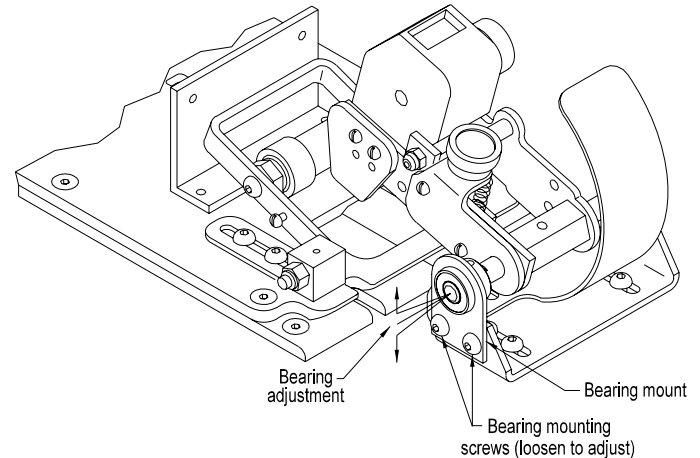

Figure 3.19

2. Slide the mount as needed. Force the side of the slot against the two screws to square it. Verify that the ink roll is centered side to side with the closure strip.
3. After tightening the screws, check the adjustment by manually depressing the printhead before applying power to the machine.

R. INKING FORCE- SIDE TO SIDE:

As the ink roll is rolled across the typeface, the 0S-006 spring (silver) on the ink roll arm determines the inking force. The surface of the ink roll must align parallel to the typeface, so all the type is properly inked. To verify this adjustment, it is necessary to jog the machine until the ink roll is in contact with the typeface. (See W. JOGGING THE CLOSER AND PRINTER MECHANISM below.)

1. With the ink roll in contact with the typeface, depress the ink roll arm slightly to see if the ink roll contacts the typeface uniformly.
2. If the ink roll is tipped, align it by slightly loosening the screw that attaches the cam follower (Figure 3.18).

SECTION III Adjustments

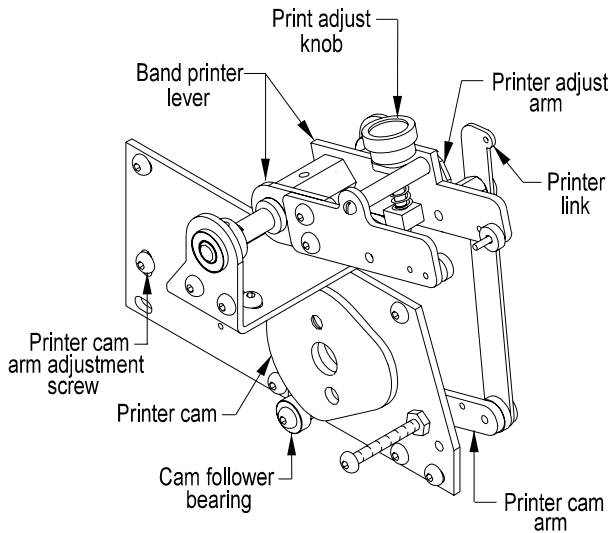

Figure 3.20

The screw hole in the ink roll cam follower is offset from center, so as the cam follower is rotated slightly, the end of the ink roll will move up or down.

3. Position the cam follower so the ink roll is parallel to the typeface and retighten the screw.

S. PRINT FORCE- SIDE TO SIDE:

The print head must be aligned so the typeface contacts the closure uniformly from side to side. Verify that the type is properly inked. (See part Q. INK ROLL ARM POSITION and part R. INKING FORCE- SIDE TO SIDE).

1. Adjust the print force to a very light setting to accentuate the variation in the print quality. Verify that the type is being properly inked. If the line of printing is not uniform, the bearing mount (Figure 3.19) can be moved vertically to raise or lower that end of the printer shaft.
2. Slightly loosen the two button head screws that hold the bearing mount.

3. Move the bearing mount only about 1/32" (1mm) and then reevaluate the print force.
4. Verify that the side-to-side location of the printhead has not changed and that the inking force is still uniform across the typeface.

T. PRINT FORCE- TOP TO BOTTOM:

If the force is not uniform from the top to the bottom of the typeface, the printed image will not be uniform. Verify that the typeface is being inked properly before proceeding.

For the band printer, check that the top of the band-head has been rotated against the spacer (item 7, Figure 5.3). If needed, the spacer can be moved slightly on its mounting screw.

The block printer can be tipped, by loosening the nut on the printer block shaft (items 21 and 4, Figure 5.4) and rotating the block around the spring pin (item 20, Figure 5.4). When the shaft is positioned properly, retighten the nut. Check to see that the printer block can be removed and replaced easily.

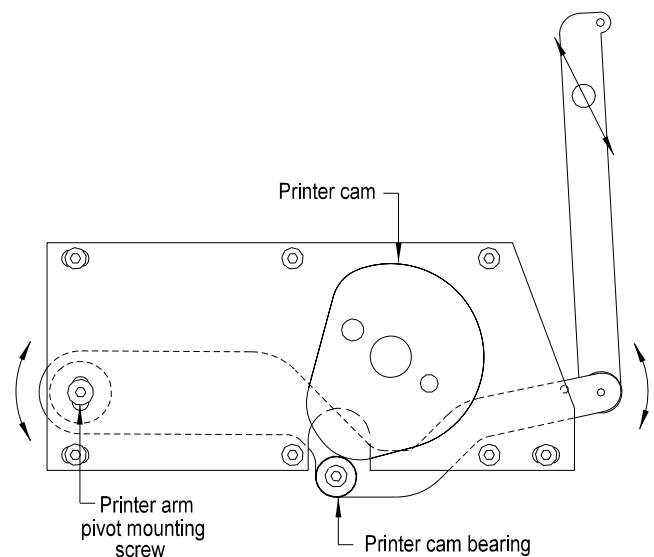

Figure 3.21

SECTION III

Adjustments

U. PRINT FORCE RANGE:

THIS PROCEDURE SHOULD ONLY BE PERFORMED BY SOMEONE WHO IS QUALIFIED TO WORK IN THE PRESENCE OF CHARGED ELECTRICAL CONTACTS AND UNGUARDED MACHINERY.

The print adjust knob (item 23, Figure 5.3) has a limited range of adjustment. It can be rotated clockwise (decreasing printing force) until it will not turn any further when a moderate torque is applied. It can be rotated counterclockwise (increasing printing force) until the turning resistance abruptly decreases, at which time turning the knob further will have no effect on the print force. The full range is about 2 1/2 turns. If the range is more limited, the printer adjust arm (item 6, Figure 5.3) is not moving freely against the lever (item 4, Figure 5.3). The two screws (item 34, Figure 5.3) need to be adjusted to allow free movement with minimum space between the lever and printer adjust arm. The screws are secured with thread locking compound, so they will not work loose.

Normally, good print quality should be attainable near the mid-point of the adjustment. If not, first verify that the type is being properly inked and that the side-to-side print force is uniform.

DO NOT USE EXCESSIVE PRINT FORCE TO COMPENSATE FOR OTHER DEFECTS.

To adjust the range of the print force:

1. Disconnect the power.
2. Remove the side access cover from the side of the closer.
3. Identify the printer cam bearing (Figure 3.21) which is behind the closer cam. While looking below the closer cam manually press and release the print head. The cam bearing will move as the print head moves.

4. Jog the mechanism until the printer cam bearing (Figure 3.21) is contacting the highest point on the lobe of the printer cam. (See W. JOGGING THE CLOSER AND PRINTER MECHANISM below.)
5. Turn the knob (item 19, Figure 5.4) clockwise until it stops.
6. Turn the knob counterclockwise 1 1/4 turns.
7. Verify there is a closure in the print position.
8. Identify the screw (Figure 3.21 and item *12, Figure 5.5) on the motor mounting plate attaching the pivot to the motor plate. (The pivot will not be visible.) Loosen the screw. As the screw (and pivot) is moved up and down, the printhead will move in the opposite direction.
9. Move the screw as high as it can go when moderate force is applied and tighten it. Check that the printhead is resting firmly on the closure, by pushing downward on the print-head.
10. Replace the access cover.
11. Verify the proper print force is attainable within the range of the adjustment knob by operating the machine. Readjust as needed.

SECTION III Adjustments

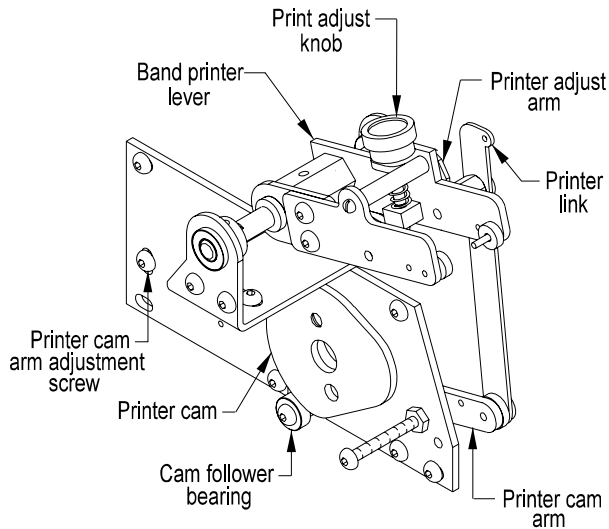

Figure 3.22

V. BANDHEAD REPLACEMENT: (Figure 3.22)

To replace the bandhead:

1. Remove the spacer, nut and screw (items 7, 25, and 32, Figure 5.3).
2. Note the position of the printhead mounting pins and bushings. There are two sets of mounting holes. The forward pin mounting position is for the European printhead, the rear mounting location is for the non-European printhead. The bushings set against the print head. For a non-European printhead there are two bushings on the right-hand side of the printhead and one on the left. For a European printhead there is one bushing on each side of the printhead. When the printer lever is removed be careful not to lose the bushings. (item 21, Figure 5.3).
3. Remove the two screws that connect the printer arm to the printer lever.
4. Slide the printer arm and bushing away from the printhead and remove the printhead.

5. To mount the printhead, place the bushings on the printhead mounting pins and reattach the printer arm to the printer lever. Pinch the printer arm and the printer lever together with the printhead between them. Tighten the two button head mounting screws so the printer arm and printer lever are parallel.
6. Reconnect the spacer and printer linkage.
7. Refer back to section R through T in this section to adjust for print quality if needed.

W. JOGGING THE CLOSER AND PRINTER MECHANISM:

For some adjustments (R. INKING FORCE- SIDE TO SIDE and U. PRINT FORCE RANGE) the mechanisms must be in a position different from the normal parked position. Since the motor has an automatic brake, it can be rotated only by applying electrical power.

Use the following procedure to jog the printer mechanism as needed:

1. Disconnect the power.
2. Remove any closure from the closing position.
3. Move the switch to the "RUN" position.
4. For a fraction of a second, apply power to the machine. A switch in the power line works well, or the power plug can be rapidly plugged and unplugged.
5. Repeat step 4 until the mechanism is in the desired position. If the mechanism moves past the desired position, continue on around and try again. If another closure moves into the closing position, remove it.
6. When finished with the adjustment move the switch to the "STOP" position and apply power so the closer will stop in the parked position.

SECTION III Adjustments

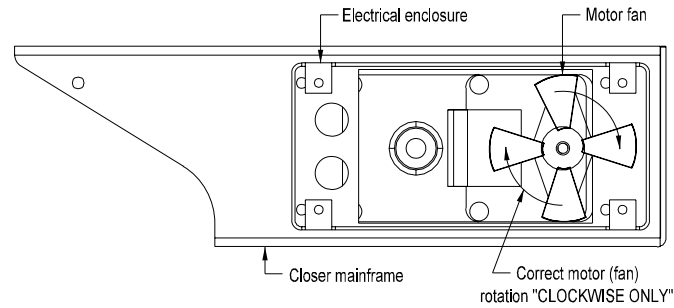

Figure 3.23

CAUTION MOTOR ROTATION.

Inadvertently rotating the motor shaft manually can damage the cam switch (Figure 3.23). If the motor is to be manually rotated **ONLY ROTATE THE MOTOR CLOCKWISE FROM THE FAN END OF THE MOTOR.**

If the motor shaft is turned in the opposite direction (counterclockwise from the fan end of the motor) the cam switch will likely be damaged.

SECTION IV Trouble Shooting

MECHANICAL TROUBLE SHOOTING

PROBLEM	SYMPTOM	CORRECTION
1. The closer does not cycle to advance a closure into the closing position. The light and motor are off.	A. Electrical power is not available.	Connect the electrical plug to an appropriate power source.
	B. The switch is in the "STOP" position.	Move the switch to the "RUN" position.
	C. The fuse is burned out.	Check the fuse and replace as needed.
2. The closer does not cycle to advance a closure to the closing position. The light is off and the motor is humming. CAUTION: IMMEDIATELY DISCONNECT THE POWER TO AVOID DAMAGING THE MOTOR. After the problem is corrected, the machine will complete its cycle when the power cord is plugged in.	A. If the printer is stopped with the type against the closure, the print pressure is excessive.	Turn the print force adjust knob clockwise as far as it will go. Refer to SECTION II Operation, Part D. ADJUSTING THE PRINT FORCE.
	B. The printer mechanism is jammed.	To determine if the printer mechanism is moving freely, depress the printhead by hand until the type contacts the closure. Look for parts that are out of place and foreign material in the printer mechanism.
	C. The pick is caught in the shield.	Look under the front of the closure track to see if the tips of the pick are located in the slots in the underside of the closure track. If not, center the pick by hand. There is spring tension applied at the back of the pick assembly which keeps the front of the pick up against the closure track. The front of the pick should move down from the track with a light pressure. Some side play in the pick is normal when the pick is not in the track slots.
	D. The closures are jammed in the closure track.	Remove any jammed closures by hand. Do not gouge or pry on the closure track. The top of the closure track can be removed if needed. Refer to the Adjustment section for instructions.

SECTION IV

Trouble Shooting

PROBLEM	SYMPTOM	CORRECTION
3. The closer does not cycle to advance a closure to the closing position. The light is on.	A. The sensor lever is not moving to the no-closure position.	Reach under the closure track at the front of the closer and try to move the sensor lever to the left. If the closer cycles, the sensor lever may need to be cleaned or adjusted. Refer to Section III, Part F. SENSOR LEVER SPRING, Part G. SENSOR LEVER STOP ADJUSTMENT, and Part H. SENSOR SWITCH ADJUSTMENT.
4. The closer cycles and the light blinks repeatedly. There is no closure between the check and pick.	A. The closer is operating properly.	Move the switch to the "STOP" position and refer to Section II, Part B. LOADING A ROLL OF CLOSURES.
5. The closer cycles and the light blinks repeatedly. There is a closure between the check and pick that does not advance.	A. The wrong closures are being used.	The 086 Model P operates with series R and RL, closures medium or heavy duty . The model 300P uses L series labels medium or heavy duty. The model 400P uses U series labels medium and heavy duty. The model 500P uses series CR labels in medium or heavy duty.
	B. The check is not adjusted properly.	See Section III, Part B. CHECK POSITION.
	C. The pick does not advance the closure.	Look under the front of the closure track to see if the tips of the pick are located in the slots at the bottom of the closure track. If it is not, center the pick by hand. The pick is held up by the pick spring located at the back of the pick assembly. The pick should move down when a light force is applied to it; when released it should move back up due to the spring tension. Some side play is normal when the pick is out of the closure track slots.
6. The closer continues to cycle while the switch in in the "STOP" position. The light does not blink.	A. The cam switch is not functioning properly.	The cam switch stops the motor in the proper position and turns on the light. See Section III, Part M. CAM SWITCH MOUNTING and SECTION VI, Wiring Diagram. The lever of the cam switch may be bent, the cam switch may be defective, or the switch cam may not be mounted properly. Correct as needed.

SECTION IV Trouble Shooting

PROBLEM	SYMPTOM	CORRECTION
7. The closer cycles even though a closure is in the bag-closing position. One or more closures are pushed out the front of the closure track.	A. The sensor lever is not detecting the closure.	See Section III, Part F. SENSOR LEVER SPRING, Part G. SENSOR LEVER STOP ADJUSTMENT, and Part H. SENSOR SWITCH ADJUSTMENT.
8. The closure in the bag-closing position is hard to remove because it is not separated from the closure strip.	A. The pick is not advancing to the correct position because the mechanism is loose.	With the power cord disconnected, reach under the front of the closure track and move the pick downward. Grasp the pick firmly and attempt to move it backward and forward. Sideplay is normal. The pick assembly should feel solid. If not, the screws which mount the pick to the pick arm or the screw that attaches the pick arm to the closer cam may be loose or the pick bearing may need replacement.
	B. The pick is not advancing to the correct position because the pick is out of adjustment.	See Section III, Part J. PICK / CLOSURE LOCATION.
	C. The height of the closure stop is not correct.	If the closure stop is not adjusted to the proper height, the closures may slip over it. Refer to Section III, Part D. CLOSURE STOP SETSCREW ADJUSTMENT. Examine the closer stop to see that it is centered in the slot in the closure track. Refer to Section III, Part C. CLOSURE STOP POSITION.
	D. The closure stop is not functioning correctly.	The closure stop may move downward under load, and may allow the closure to pass. Verify that the two gold springs are extended between the stop and mounting screw. Approximately 1/2 lb. (200 g) of force should be required to depress the tip of the stop. If the upward force is not adequate, the forward force of the closure on the tip of the stop will cause the tip to rotate downward and allow the closure to slide over it. The gold springs may become stretched while they are being attached if they are not handled carefully. Replace them if needed.

SECTION IV

Trouble Shooting

PROBLEM	SYMPTOM	CORRECTION
9. The closure strip will not slide freely through the closure track.	A. The closures are snagging on the closure stop setscrew.	See Section III Part E. CLOSURE STOP SETSCREW ADJUSTMENT.
	B. The closure track is fouled with foreign material.	See Section III Part B. TOP CLOSURE TRACK REMOVAL to open the track and clean it.

PRINT QUALITY TROUBLE SHOOTING

1. The entire printed image is light.	A. The ink roll is depleted.	Replace the ink roll. If the print force has been increased, readjust it to the minimum setting for good print quality.
	B. The inking force is inadequate.	Verify that the silver colored spring (OS-119) spring is in good condition and is connected between the ink roll arm and the printer link.
	C. The print force is too light.	Turn the print force knob 1/4 turn counterclockwise. If both RL and SL series closures are being used in the same 086-200, the print force should be readjusted at each changeover. If the knob turns easily and the printed image does not improve, refer to Section III Part U. PRINT FORCE RANGE.
2. The top of the line of printed image is light.	A. The type is not completely inked.	Refer to Section III Part Q. INK ROLL ARM POSITION. Also for the gripline printer, the type may not be properly installed. Refer to Section II, Part C. 2, b.
	B. The printhead is tipped.	Refer to Section III Part T. PRINT FORCE-TOP TO BOTTOM.
3. The printed image is light on one end.	A. The ink roll is tipped.	Refer to Section III Part R. INKING FORCE-SIDE TO SIDE.
	B. The printhead is tipped.	Refer to Section III Part S. PRINT FORCE-SIDE TO SIDE.
4. The printed image has light or missing characters.	A. The height of the type is uneven.	With usage type wears. For the bandheads, some of the most-used characters are repeated on some bands. Replace the bandhead if needed. For the type block, replace worn type.

SECTION IV Trouble Shooting

PROBLEM	SYMPTOM	CORRECTION
5. The printed characters have wide lines which also may be dark on the edges and light in between.	A. The print force is too heavy.	Turn the print force knob 1/4 turn clockwise at a time and test the results. Continue adjusting the print pressure until the printed image becomes light and then back up the knob 1/4 turn.
6. The printed characters are irregular and fuzzy.	A. The type is dirty.	Clean the type with a cloth or tissue. Isopropyl alcohol swabs work well. For the gripline block printer, remove the block from the printer lever. For the band printer, remove the ink roll while cleaning the type or rotate the printhead by hand to gain better access to the typeface. Store the closures in an area where they will stay clean and not gather dust and debris. Always keep the printer cover closed. Do not soak type in alcohol or other solvents as it will swell the type and make it unusable.
7. The print image is smeared.	A. The closure track is dirty.	If the print image extends to the edge of the closure, it will smear in the closure track. Once the ink starts to smear, the problem will worsen rapidly. Refer to Section III, Part B. TOP CLOSURE TRACK REMOVAL and clean the top and bottom of the closure track grooves with a tissue or soft cloth. Isopropyl alcohol works well for this.
	B. The ink roll is not working properly.	Do not attempt to recondition a used ink roll by adding solvent or stamp pad ink to the roll.
8. The ink is smeared on the back side of the closure.	A. The type is printing on the closure track when no closure is at the print location.	Refer to Section II, Part B. LOADING A ROLL OF CLOSURES.

WARNING: DO NOT ORDER PARTS BY ITEM NUMBER.

Be sure to order by Part Number and Description. Please list the Serial Number of the machine for which the parts are being ordered.

SECTION V Parts Identification

PARTS ORDERING PROCEDURE

IMPORTANT: When ordering parts, **ALWAYS:**

- 1) Specify on the order the **TYPE, MODEL,** and **SERIAL NUMBER** of the machine for which the parts are being ordered. This information can be found on the machine nameplate.
- 2) **DO NOT** order by item number. Order by **PART** or **KIT** number.

To order individual parts, be sure to do the following:

- 1) Identify the needed parts by referring to the assembly illustrations. Each part is assigned an item number on the illustration.
- 2) Refer to the parts list. Locate the item number for the part to be ordered. Opposite the item number is the part number and description for that part.
- 3) Again, specify on the order the **TYPE, MODEL,** and **SERIAL NUMBER** for which the parts are being ordered. This information is located on the machine nameplate.

SECTION V

Parts Identification

WARNING: DO NOT ORDER PARTS BY ITEM NUMBER.
Be sure to order by Part Number and Description. Please list the Serial Number of the machine for which the parts are being ordered.

PARTS COMMON

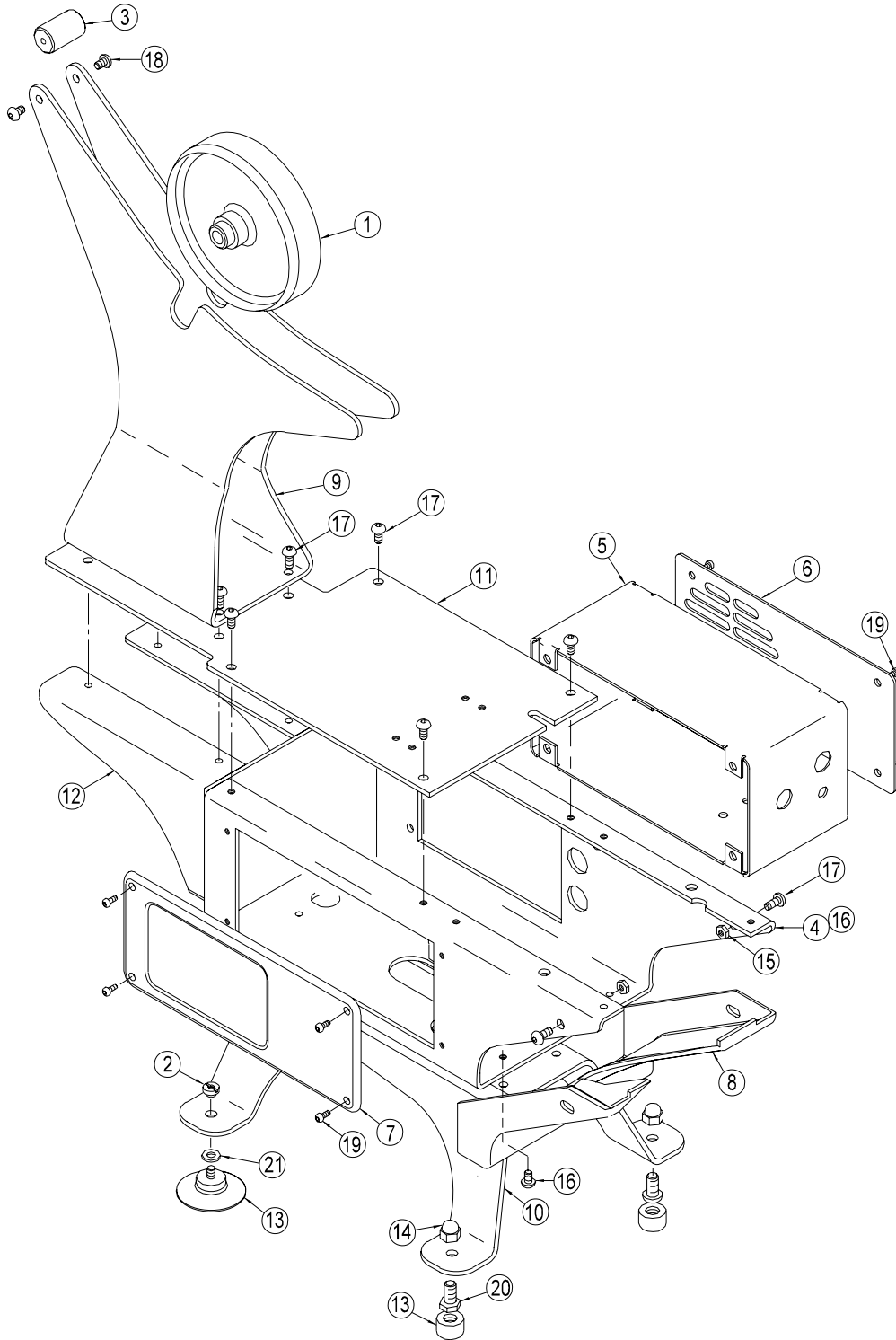

Figure 5.1

WARNING: DO NOT ORDER PARTS BY ITEM NUMBER.

Be sure to order by Part Number and Description. Please list the Serial Number of the machine for which the parts are being ordered.

SECTION V

Parts Identification

PARTS COMMON

(Figure 5.1)

PARTS LIST

Item No.	Part No.	Description	Qty.	Item No.	Part No.	Description	Qty.
1	00-000594	Hub - Lok - RJ - Model 200P	1	12	00-001069	Bracket - Reel Support	1
	00-000890	Hub - L Labels - Model 300P	1	13	**P05-00019	Foot - Standard	4
	00-000891	Hub - U Labels - Model 400P	1		*P05-00032	Cup - Suction	4
	00-001075	Hub - CR Labels - Model 500P	1	14	**P23-00286	Nut - Acorn	4
2	*00-000673	Nut	4	15	F03-190FS	Nut - 10-32UNF - Hex	2
3	00-000893	Spacer - Frame - Models 200P, and 300P	1	16	F11-190F04S	Screw - 10-32UNF X 1/4 Lg Skt Btn Hd	8
	00-000895	Spacer - Frame - Model 400P		17	F11-190F06S	Screw - 10-32UNF x 3/8 Lg Skt Btn Hd	11
	00-001076	Spacer - Frame - Model 500P	1	18	F11-190C06S	Screw - 10-24UNC x 3/8 Lg Skt Btn Hd	2
4	00-001002	Frame - Main	1	19	F11-164C04S	Screw - 8-32UNC x 1/4 Lg Skt Btn Hd	8
5	00-001007	Enclosure - Electrical	1	20	**F13-250C06	Screw - 1/4-20UNC x 3/8 Lg Hex Hd	4
6	00-001008	Cover - Electrical Enclosure	1	21	*F14-187S	Washer	4
7	00-001010	Cover - Access	1				
8	00-001011	Shield	1				
9	00-001027	Support - Narrow Roll Models 200P and 300P	1				
	00-001026	Support - Wide Roll Model 400P	1				
	00-001074	Support - Medium Model 500P	1				
10	00-001046	Stand - Printer	1				
11	00-001048	Plate - Top - Printer	1				
				*	These parts are available in kit Z0065004 Kit - Suction Cups and may be ordered as such.		
				**	These parts are available in kit Z0065006 Kit - Feet and may be ordered as such.		

SECTION V Parts Identification

WARNING: DO NOT ORDER PARTS BY ITEM NUMBER.
Be sure to order by Part Number and Description. Please list the Serial Number of the machine for which the parts are being ordered.

PARTS COMMON 2

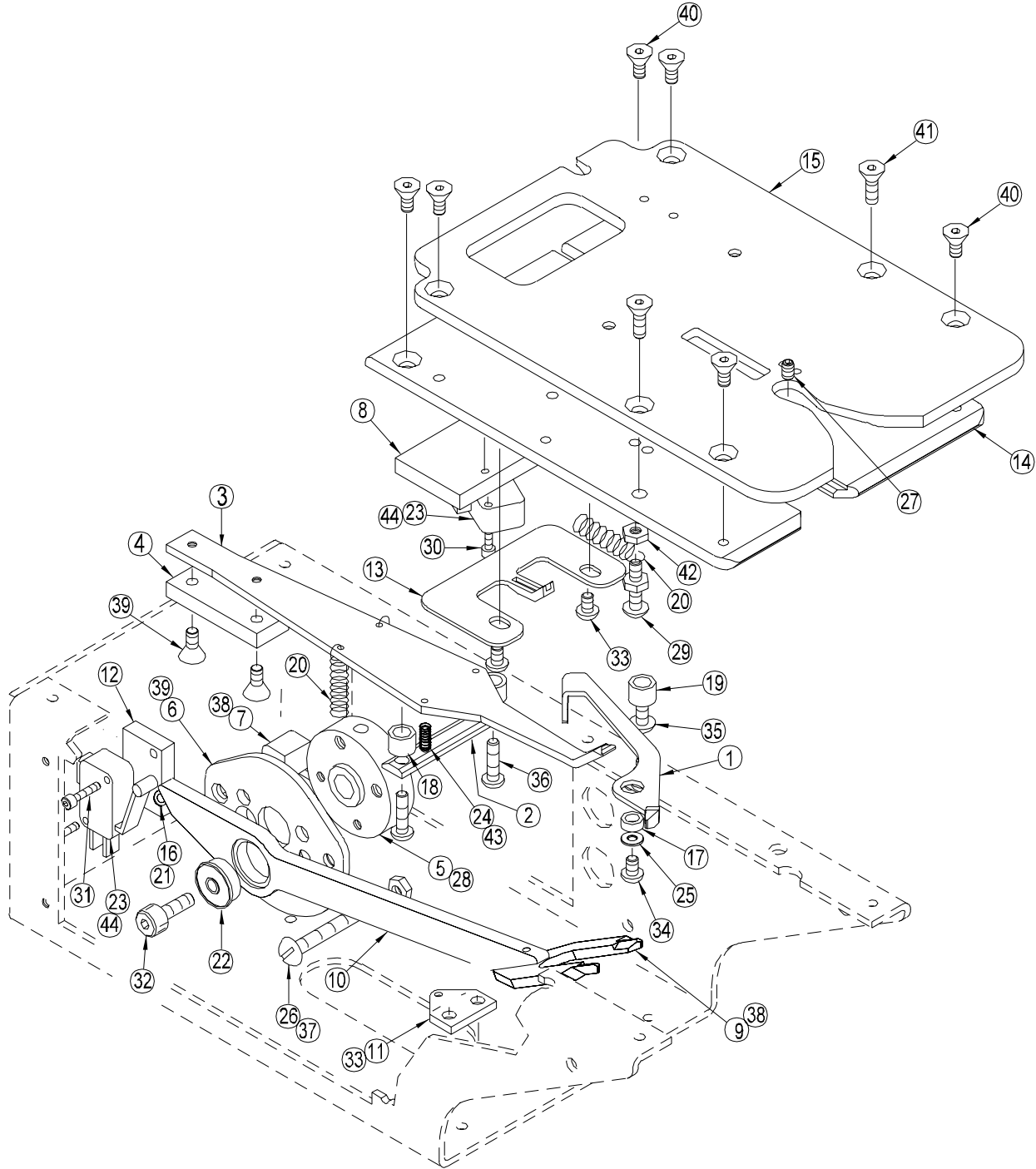

Figure 5.2

WARNING: DO NOT ORDER PARTS BY ITEM NUMBER.
 Be sure to order by Part Number and Description. Please list the Serial Number of the machine for which the parts are being ordered.

SECTION V Parts Identification

PARTS COMMON 2 (Figure 5.2)

PARTS LIST

Item No.	Part No.	Description	Qty.	Item No.	Part No.	Description	Qty.
1	00-001012	Lever - Sensor	1	27	F06-164C04N	Screw - 8-32UNC x 1/4 Lg Skt Set	1
2	00-001013	Mount - Stop	1	28	F06-190C06	Screw - 1/4-20UNC x 3/8 Lg Skt - Set	1
3	00-001014	Stop - Closure	1	29	F07-164C16S	Screw - 8-32UNC x 1" Lg Mach Hd	1
4	00-001015	Plate - Wear	1	30	F10-112C10S	Screw - 4-40UNC x 5/8 Lg Skt Hd Cap	2
5	00-001018	Hub - Cam	1	31	F10-112C16S	Screw - 4-40UNC x 1" Lg Skt Hd Cap	2
6	00-001019	Cam	1	32	F10-250C12	Screw - 1/4-20UNC x 3/4 Lg Skt Hd Cap	1
7	00-001020	Cam - Switch	1	33	F11-190F04S	Screw - 10-32UNF x 1/4 Lg Skt Btn Hd	2
8	00-001021	Block - Sensor Switch	1	34	F11-190F05S	Screw - 10-32UNF x 5/16 Lg Skt - Btn Hd	1
9	00-001022	Pick	1	35	F11-190F07S	Screw - 10-32UNF x 7/16 Lg Skt Btn Hd	1
10	00-001023	Arm - Pick	1	36	F11-190F10S	Screw - 10-32UNF x 5/8 Lg Skt Btn Hd	2
11	00-001024	Bracket - Spring Mount	1	37	F07-190F28S	Screw - 10-32UNF x 1 3/4 Mach Hd	1
12	00-001025	Block - Cam Switch	1	38	F12-138C06S	Screw - 6-32UNC x 3/8 Lg Skt Flt Hd	3
13	00-001029	Check	1	39	F12-164C06S	Screw - 8-32UNC x 3/8 Lg Skt Flt Hd	3
14	00-001041	Track - Bottom - Printer	1	40	F12-190F06S	Screw - 10-32UNF x 3/8 Lg Skt Flt Hd	6
15	00-001042	Track - Top - Lok - Model 200P	1	41	F12-190F10S	Screw - 10-32UNF x 5/8 Lg Skt Flt Hd	2
	00-001123	Track - Top - L Label Model 300P	1	42	F03-164CS	Nut - 8-32UNC - Hex	2
	00-001043	Track - Top - Series U, CR, and CS Labels - Models 400P and 500P	1	43	0S-118	Spring	2
16	08-002026	Pin - Drive	1	44	P11-00323	Terminal	5
17	BS312203125	Bushing	1				
18	BS375203375	Bushing	2				
19	BS375257281	Bushing	1				
20	0S-012	Spring (gold in color)	3				
21	0S-117	Spring - Extension	1				
22	P02-00064	Bearing - Pick	1				
23	P12-00085	Switch - Limit	2				
24	P23-00169	Pin - Drive	2				
25	F01-190S	Washer - No. 10 - Flat	1				
26	F03-190FS	Nut - 10-32UNF - Hex	1				

SECTION V

Parts Identification

WARNING: DO NOT ORDER PARTS BY ITEM NUMBER.
 Be sure to order by Part Number and Description. Please list the Serial Number of the machine for which the parts are being ordered.

PRINTER - BAND

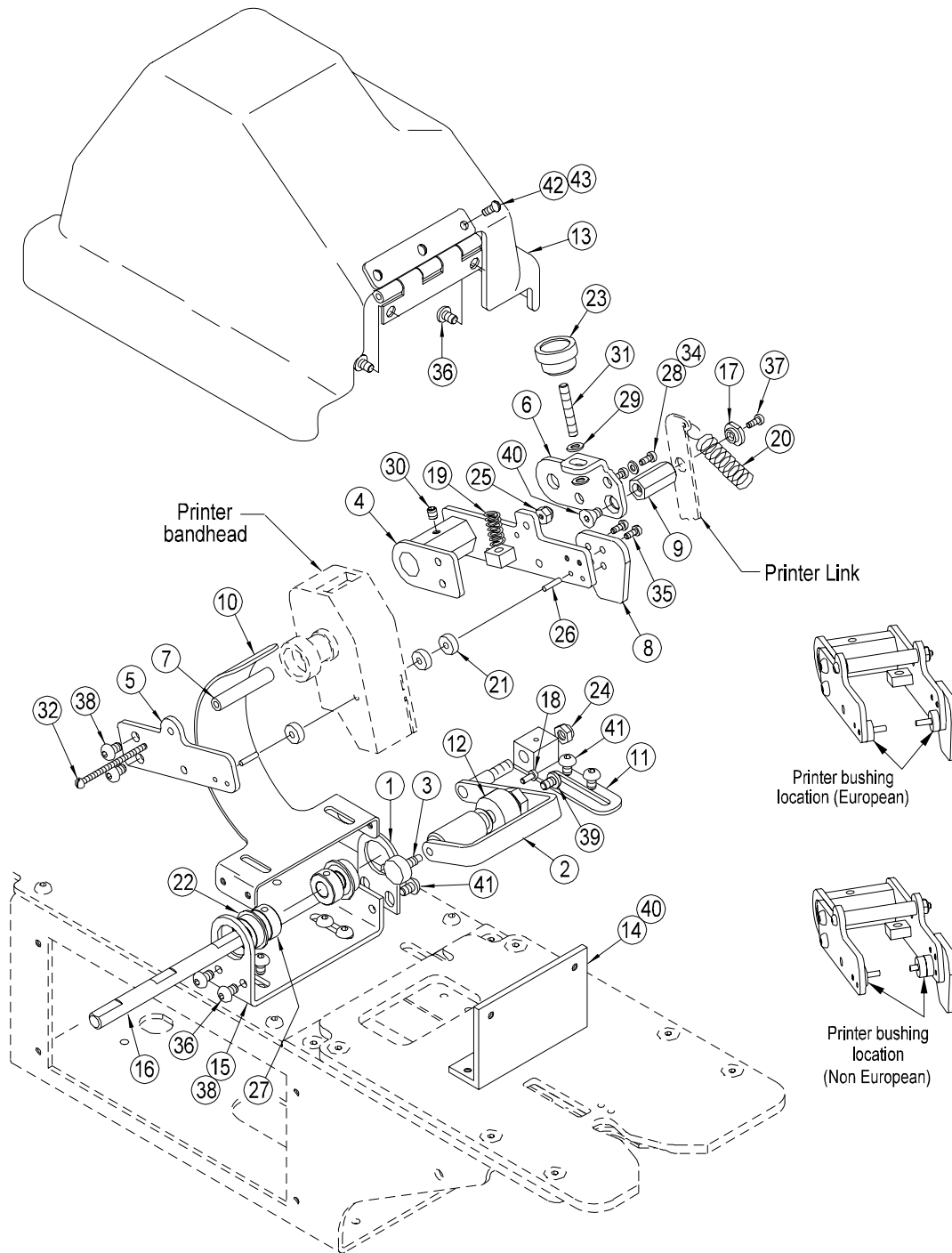

Figure 5.3

WARNING: DO NOT ORDER PARTS BY ITEM NUMBER.
 Be sure to order by Part Number and Description. Please list the Serial Number of the machine for which the parts are being ordered.

SECTION V Parts Identification

PRINTER - BAND

(Figure 5.3)

PARTS LIST

Item No.	Part No.	Description	Qty.	Item No.	Part No.	Description	Qty.
1	00-000513	Mount - Bearing	1	24	P23-00068	Nut - 1/4-28UNF ESNA	1
2	00-000719	Arm - Ink Roll	1	25	P23-00198S	Nut - 5-40UNC - ESNA	1
3	00-000721	Knob - Ink Roll - Model PB (non European)	1	26	P23-00169	Pin - Drive	2
	00-000723	Knob - Ink Roll - Model PC (European)	1	27	P29-00003	Collar - Set	2
4	00-001051	Lever - Band Printer	1	28	F01-138S	Washer - No. 6 Flt	2
5	00-001053	Arm - Band Printer	1	29	F01-190S	Washer - No. 10 Flt	2
6	00-001054	Arm - Printer - Adjust	1	30	F06-190F03S	Screw - 10-32UNF x 3/16 Lg Skt Set	1
7	00-001055	Spacer - Band Printer	1	31	F06-190F20S	Screw - 10-32UNF x1 1/4 Lg Skt Set	1
8	00-001056	Cam - Ink Roll	1	32	F07-125C28S	Screw - 5-40UNC x 1 3/4 Lg Rnd Mach Hd	1
9	00-001058	Spacer (European)	1	33	F11-125C04S	Screw - 5-40UNC x 1/4 Lg Skt Btn Hd	2
	00-001059	Spacer (non European)	1	34	F11-138C04S	Screw - 6-32UNC x 1/4 Lg Skt Btn Hd	2
10	00-001060	Shoe - Strip	1	35	F07-125C04S	Screw - 5-40UNC x 1/4 Lg Rnd Hd Mach	2
11	00-001062	Mount - Ink Roll Arm	1	36	F11-164C03S	Screw - 8-32UNC x 3/16 Lg Skt Btn Hd	4
12	00-001063	Follower - Cam - Model PC (European)	1	37	F11-138C08S	Screw - 6-32UNC x 1/2 Lg Skt Btn Hd	6
	00-001064	Follower - Cam - Model PB (non European)	1	38	F11-190F04S	Screw - 10-32UNF x 1/4 Lg Skt Btn Hd	4
13	00-001070	Cover - Printer	1	39	F11-190F06S	Screw - 10-32UNF x 3/8 Lg Skt Btn Hd	1
14	00-001071	Bracket - Cover Mount	1	40	F12-164C05S	Screw - 8-32UNC x 5/16 Lg Skt Hd Flt	3
15	00-001078	Bracket - Bearing	1	41	F11-164C04S	Screw - 8-32UNC x 1/4 Lg Skt Btn Hd	4
16	00-001077	Shaft - Printer	1	42	P23-00111	Nut - 6-32UNC - ESNA	3
17	08-001050	Mount - Pivot	1	43	F07-138C06S	Screw - 6-32UNC x 3/8 Lg Mach Hd	3
18	08-002026	Pin - Drive	1				
19	0S-119	Spring - Compression	1				
20	0S-006	Spring (silver in color)	1				
21	BS375109125	Bushing (non European)	3				
	BS375109125	Bushing (European)	2				
22	P02-00066	Bearing	2				
23	P17-00125	Knob	1				

SECTION V

Parts Identification

WARNING: DO NOT ORDER PARTS BY ITEM NUMBER.
Be sure to order by Part Number and Description. Please list the Serial Number of the machine for which the parts are being ordered.

BLOCK - PRINTER

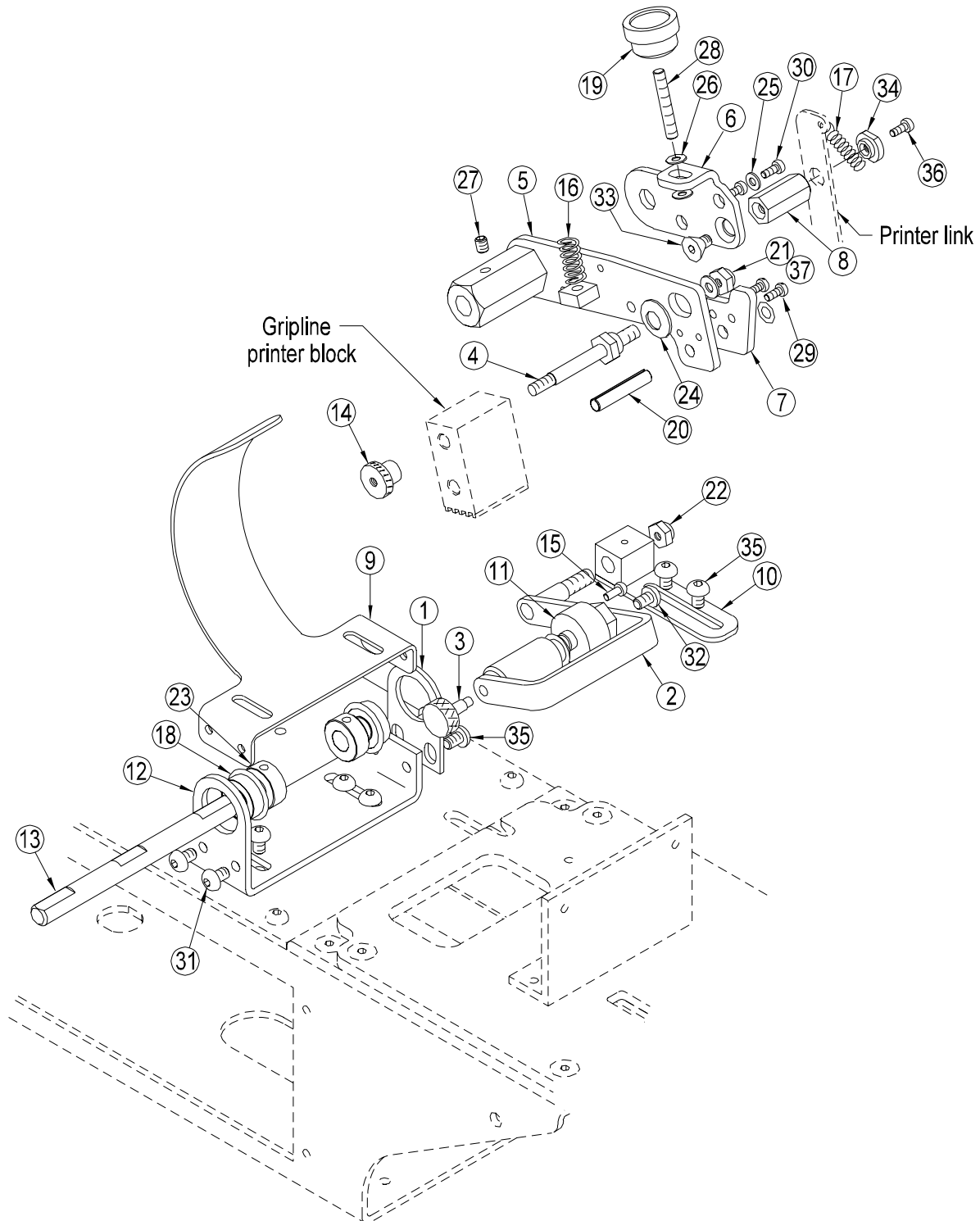

Figure 5.4

WARNING: DO NOT ORDER PARTS BY ITEM NUMBER.
 Be sure to order by Part Number and Description. Please list the Serial Number of the machine for which the parts are being ordered.

SECTION V Parts Identification

BLOCK - PRINTER

(Figure 5.4)

PARTS LIST

Item No.	Part No.	Description	Qty.	Item No.	Part No.	Description	Qty.
1	00-000513	Mount - Bearing	1	22	P23-00068	Nut - 1/4-28UNF ESNA	1
2	00-000719	Arm - Ink Roll	1	23	P29-00003	Collar - Set	2
3	00-000721	Knob - Ink Roll - Model PD Non European	1	24	P36-00014	Washer - Belleville	1
	00-000723	Knob - Ink Roll - Model PE European	1	25	F01-138S	Washer - No. 6 Flt	2
4	00-000733	Shaft - Printer Block	1	26	F01-190S	Washer - No 10 Flt	2
5	00-001052	Lever - Block Printer	1	27	F06-190F03S	Screw - 10-32UNF x 3/16 Lg Skt Set	1
6	00-001054	Arm - Printer - Adjust	1	28	F06-190F20S	Screw - 10-32UNF x1 1/4 Lg Skt Set	1
7	00-001057	Cam - Ink Block Printer	1	29	F07-125C04S	Screw - 5-40UNC x 1/4 Lg Mach Hd	2
8	00-001058	Spacer	1	30	F11-138C04S	Screw - 6-32UNC x 1/4 Lg Skt Btn Hd	2
9	00-001060	Shoe - Strip	1	31	F11-164C03S	Screw - 8-32UNC x 3/16 Lg Skt Btn Hd	6
10	00-001062	Mount - Ink Roll Arm	1	32	F12-164F06S	Screw - 8-32UNF x 3/8 Lg Skt Btn Hd	1
11	00-001064	Follower - Cam - Model PD Non European	1	33	F12-190F04S	Screw - 10-32UNF x 1/4 Lg Skt Hd Flt	2
	00-001063	Follower - Cam - Model PE European	1	34	08-001050	Mount - Pivot	1
12	00-001078	Bracket - Bearing	1	35	F11-164C04S	Screw - 8-32UNC x 1/4 Lg Skt Btn Hd	4
13	00-001077	Shaft - Printer	1	36	F11-138C08S	Screw - 6-32UNC x 1/2 Lg Skt Btn Hd	1
14	08-000301	Knob - Locking	1	37	08-000076	Washer	1
15	08-002026	Pin - Drive	1				
16	0S-119	Spring - Compression	1				
17	0S-006	Spring (silver in color)	1				
18	P02-00066	Bearing	2				
19	P17-00125	Knob	1				
20	P23-00007	Pin - Spring	1				
21	P23-00061	Nut - 10-32UNF - ESNA	1				

SECTION V

Parts Identification

WARNING: DO NOT ORDER PARTS BY ITEM NUMBER.
 Be sure to order by Part Number and Description. Please list the Serial Number of the machine for which the parts are being ordered.

PRINTER OPERATING LINKAGE

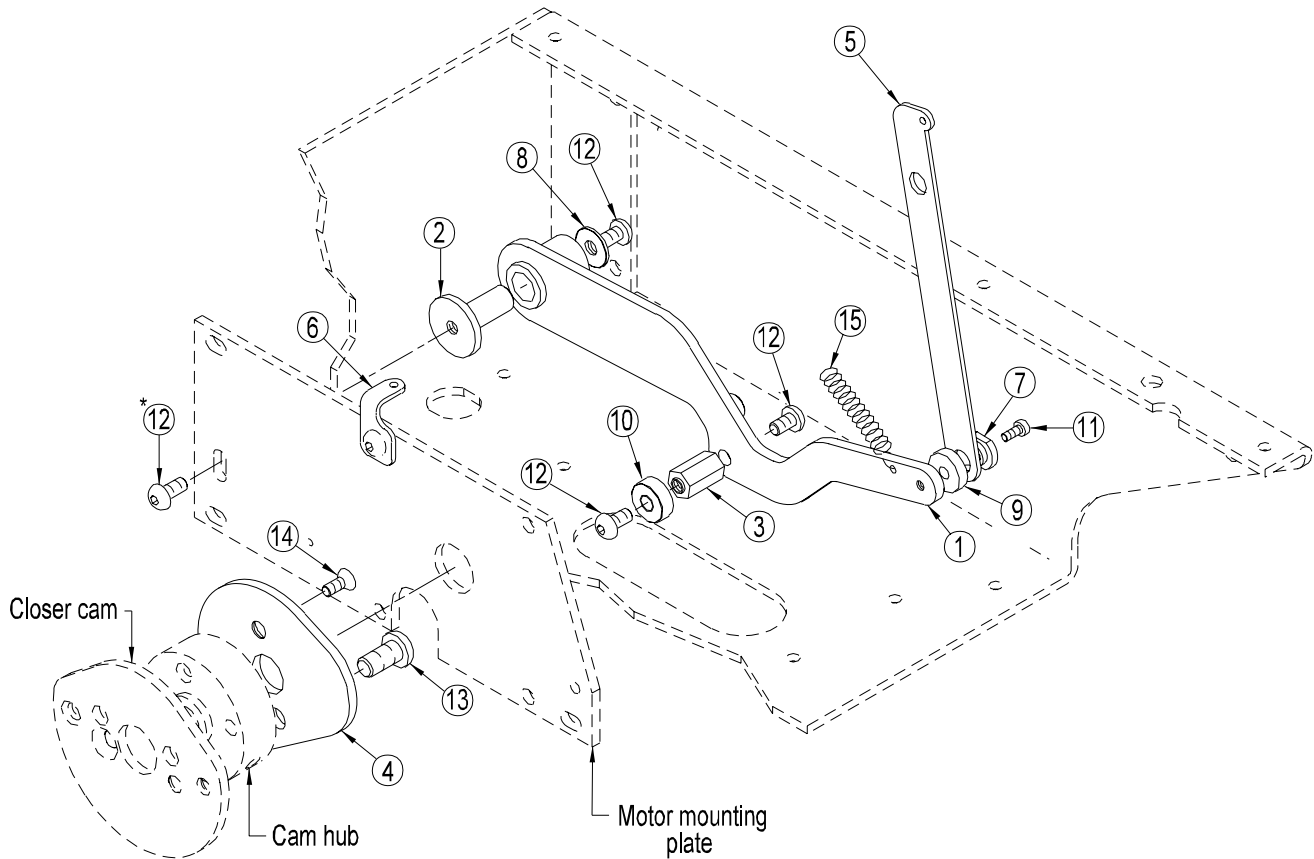

Figure 5.5

PARTS LIST

Item No.	Part No.	Description	Qty.	Item No.	Part No.	Description	Qty.
1	00-001065	Arm - Printer - Cam	1	11	F11-138C06S	Screw - 6-32UNC x 3/8 Lg Skt Btn Hd	1
2	00-001066	Pivot - Printer	1	*12	F11-190F06S	Screw - 10-32UNF x 3/8 Lg Skt Btn Hd	2
3	00-001067	Post - Bearing Mount	1	13	F11-250C08S	Screw - 14-20UNC x 1/2 Lg Skt Btn Hd	1
4	00-001068	Cam - Printer	1	14	F12-164C06S	Screw - 8-32UNC x 3/8 Lg Skt Flt Hd	1
5	00-001072	Link - Printer	1	15	0S-120	Spring - Extension	1
6	00-001079	Bracket - Printer Spring	1				
7	08-001050	Mount - Pivot	1				
8	0W-001SP	Washer	1				
9	BS375156125	Bushing	1				
10	P02-00066	Bearing - Cam	1				

* This part referred to on page 3.11

WARNING: DO NOT ORDER PARTS BY ITEM NUMBER.
 Be sure to order by Part Number and Description. Please list the Serial Number of the machine for which the parts are being ordered.

SECTION V Parts Identification

ELECTRICAL COMPONENTS

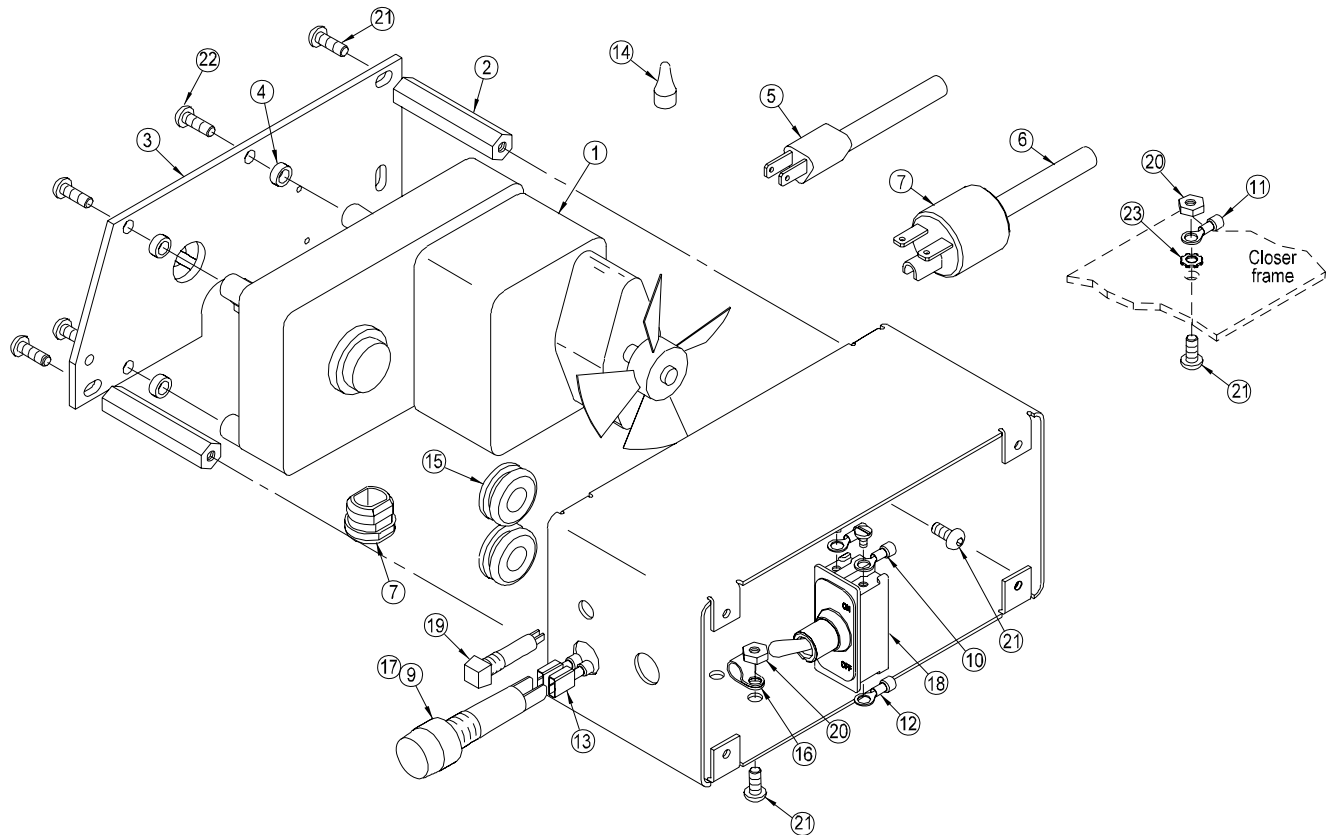

Figure 5.6
PARTS LIST

Item No.	Part No.	Description	Qty.	Item No.	Part No.	Description	Qty.
1	00-001000	Motor - 115VAC	1	14	P11-00314	Joint - Wire	1
	00-001001	Motor - 230VAC	1	15	P11-00478	Grommet	2
2	00-001017	Post - Motor Mounting	3	16	P11-00485	Clamp - Cord	1
3	00-001047	Plate - Motor Mounting	1	17	P11-00270	Fuse - 115VAC	1
4	BS312203125	Bushing	3		P11-00616	Fuse - 220 - 240VAC	1
5	P11-00064	Cord - Motor - 115VAC	1	18	P12-00043	Switch - Toggle	1
6	P11-00019	Cord - Motor - 230VAC	72"	19	P12-00193	Light - 115VAC	1
7	P11-00031	Strain Relief	1		P12-00194	Light - 230VAC	1
8	P11-00033	Plug - Motor - 230VAC	1	20	F03-190FS	Nut - 10-32UNF - Hex	3
9	P11-00042	Holder - Fuse	1	21	F11-190F06S	Screw - 10-32UNF x 3/8 Lg	7
10	P11-00066	Terminal - Closed	3			Skt Btn Hd	7
11	P11-00144	Terminal - Closed	1	22	F11-190C08S	Screw - 10-24UNC x 1/2 Lg	4
12	P11-00221	Terminal - Closed Loop	1			Skt Btn Hd	4
13	P11-00274	Terminal - Spade	2	23	F17-190S	Washer - Star	1

SECTION VI Wiring Diagrams

086 WIRING DIAGRAM

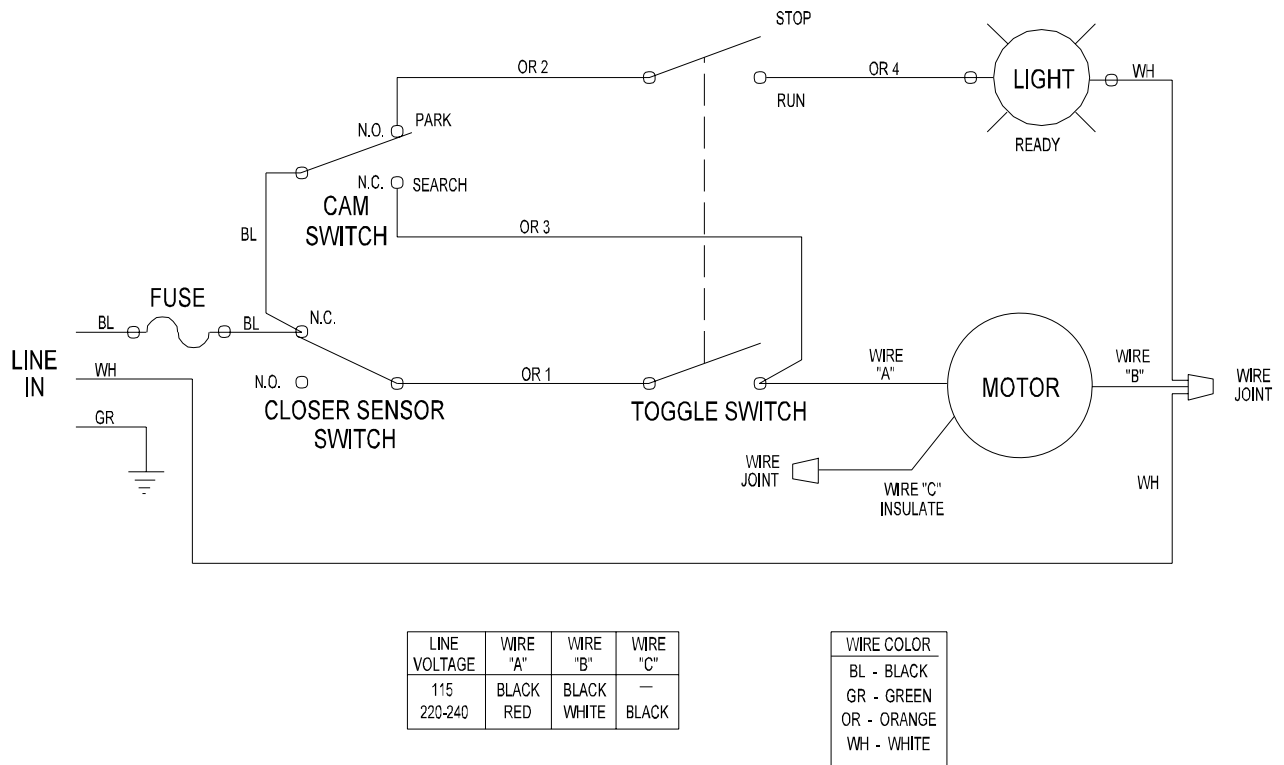
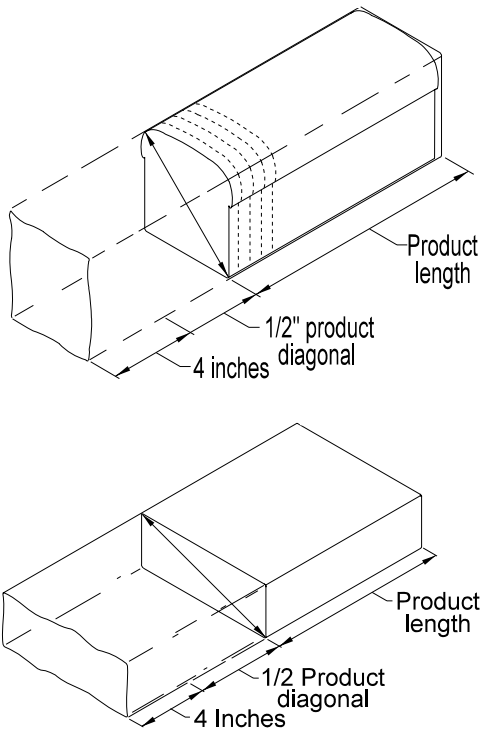

Figure 5.1

APPENDIX

BAG LENGTH FORMULAS



TO DETERMINE THE PROPER BAG LENGTH * FOR A CONSISTENTLY SHAPED PRODUCT (E.G. Bread, Bun Clusters, Trays, English Muffins, etc.) FOLLOW THIS FORMULA:

TOTAL BAG LENGTH EQUALS LENGTH OF PRODUCT PLUS 1/2 OF THE DIAGONAL OF THE PRODUCT END PLUS 4 INCHES.

TO DETERMINE THE PROPER BAG LENGTH FOR A LOOSE BULK PRODUCT (E.G. Oranges, Potatoes, Sugar, Ice, Macaroni, etc.) FOLLOW THIS PROCEDURE:

1. Fill bag to desired weight using samples of the product to be closed.
2. Close bag with the proper Striplok closure.
3. Check length of the bag above the closure. The proper bag length allows 4" of bag above closure (not including Lip of bag).



* Normal variations in size and density of products will occur. Oranges, grapefruit and potatoes dehydrate as the season progresses; bakery products vary due to over proofing; and density of ice will change because of certain manufacturing techniques. Therefore, the above bag length formulas take into account these variations to give maximum semi-automatic bag closing dependability.

APPENDIX

BAGNECK TRIMMER OPERATION AND MAINTENANCE



Figure A.1



Figure A.2

The bagneck trimming accessory described here is for use with the 086 Semiautomatic bag closing machine. Its purpose is to shear off the upper bag neck material during the closing cycle. The following information explains how to correctly operate and maintain this optional feature.

A. BAGNECK TRIMMER OPERATION:

To operate the trimmer follow these suggestions.

1. Grasp the product with one hand at the base of the bagneck nearest the product. Grasp the top of the bag with the other.
2. Insert the top of the bagneck into the end of the trimmer slot first, slightly ahead of the lower part of the bagneck (Figure A.1). Be sure the shear blade swivels into the shearing position.
3. Press the lower bagneck into the closure to close the package (Figure A.2).
4. Pull back on the top of the bagneck with a slight upward pressure to shear the bag (Figure A.3).
5. The bagneck is smoothly sheared, closed and the closer is ready for the next cycle (Figure A.4).



Figure A.3



Figure A.4

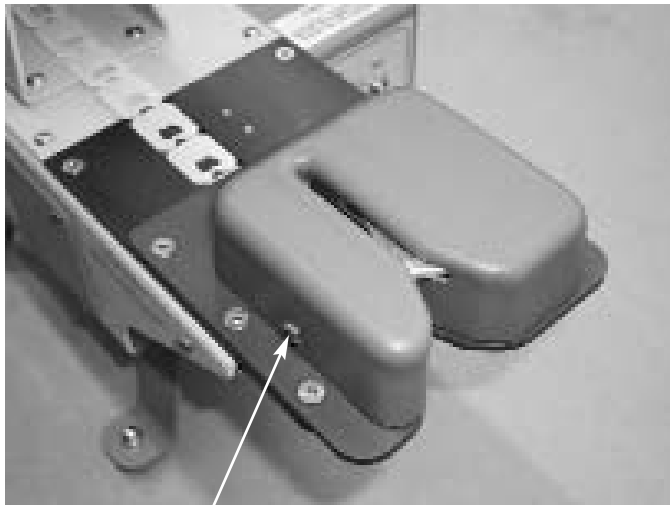

Guard mounting screws (2)

Figure A.5

B. REMOVE THE TRIMMER GUARD: (Figure A.5 & A.6)

1. Loosen the two guard mounting screws located on the side of the trimmer assembly.
2. Use the end of a pencil to push the front of the carriage backward away from the front of the closer and lift the trimmer cover off. This exposes the trimmer shear blade (Figure A.6).

CAUTION: THE SHEAR BLADE IS MADE OF A CERAMIC MATERIAL AND IS EXTREMELY SHARP. EXTRA CARE SHOULD BE TAKEN TO ENSURE THE SAFE HANDLING OF THIS BLADE.

C. SHEAR BLADE “LOCKOUT”

The shear blade mechanism can be “locked out” of its operating position. This is an option if the operator wants to close a product without shearing off the top of the bag.

1. Remove the trimmer guard as described in “B” above.
2. Carefully swivel the blade assembly fully open and turn the set screw into the carriage until it is flush with the top of the hole (Figure A.7). The blade assembly is now in the locked-out position.

Shear blade in operating position

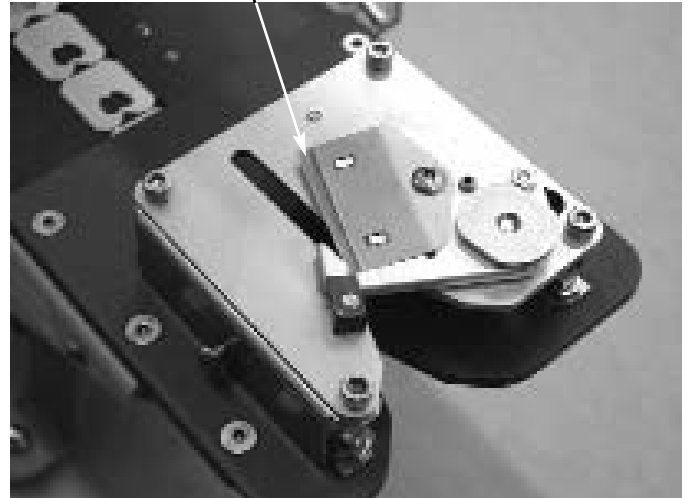
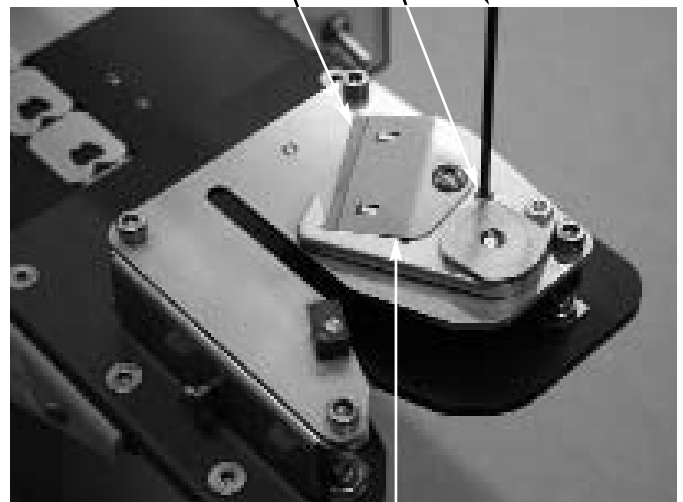

Figure A.6
(cover removed)

3. Replace the guard and tighten the mounting screws.

Lockout set screw
Shear blade in lock-out position
Allen hex key



Blade retainer

Figure A.7

APPENDIX

D. REMOVING AND INSTALLING A NEW BLADE (Figures A.7 & A.8):

Note: The shear blade is made of a ceramic material. This material is very hard and therefore quite brittle. Do not attempt to flex the blade as it will break.

1. Remove the trimmer guard as described in “B” above.
2. Locate the locking set screw located just in back of the blade retaining screw.
3. Carefully swivel the blade assembly fully open and turn the set screw into the carriage until it is flush with the top of the hole. The set screw locks the carriage assembly preventing it from moving while the shear blade is being changed.
4. Loosen and remove the blade retaining screw. Lift the blade retainer from the open (right-hand) side of the carriage assembly.

The shear blade is double edged. When in the operating position only one half of one edge of the blade is used to shear the bag. The shear blade can be mounted in four different positions to get the most out of a single blade. To keep track of the used blade positions, use a felt pen to mark the used portion and or side of the blade being changed (Figure A.8).

5. To remove the shear blade, lift **ONLY** from the right side of the blade. Turn the blade so it uses one of the three remaining unused blade surfaces and set it back onto the carriage surface. Be sure the blade slots are over the two mounting posts provided in the carriage assembly.

Mark used portion of blade.



Figure A.8

Use thumb and forefinger to safely replace shear blade.

6. Carefully replace the blade retainer onto the carriage and tighten the mounting screw.
7. Screw the locking set screw out of the carriage allowing the carriage assembly to swivel into shearing position.
8. Replace the trimmer guard over the trimmer assembly and retighten the guard mounting screws.

CAUTION: NEVER OPERATE THE TRIMMER WITHOUT ALL GUARDS IN PLACE. THE SHEAR BLADE IS EXTREMELY SHARP.

KIT Z0086007 - TRIMMER - BAG NECK LOK KIT Z0086008- TRIMMER - BAG NECK LABEL

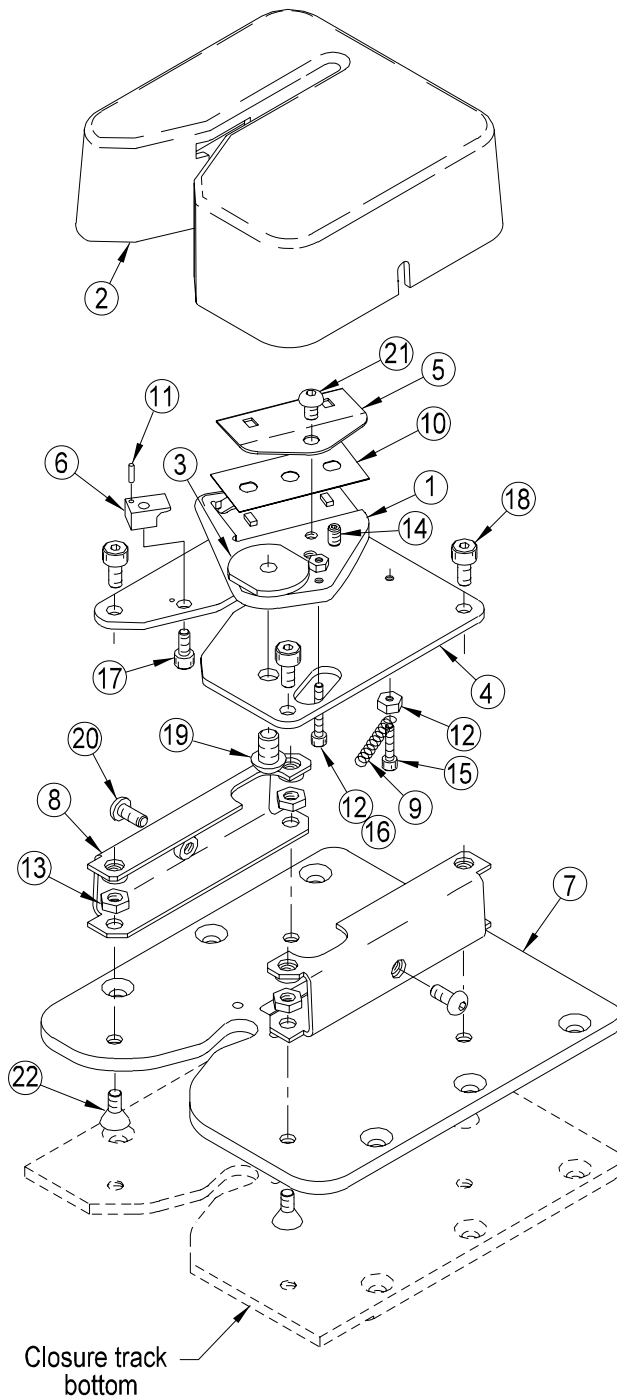

PARTS LIST

Item No.	Part No.	Description	Qty.
1	00-001030	Carriage - Blade	1
2	00-001031	Guard	1
3	00-001033	Pivot - Carriage	1
4	00-001034	Plate - Shear Blade	1
5	00-001035	Retainer - Blade	1
6	00-001036	Stop - Carriage	1
7	00-001037	Track - Top - Model 200P	1
	00-001044	Track - Top - Lok - Model 200P	1
	00-001045	Track - Top - Models 400P and 500P	1
	00-001124	Track - Top - Model - 300P	1
8	00-001039	Mount	2
9	0S-082	Spring	1
10	P17-00123	Blade - Shear	1
11	P23-00216	Pin - 1/16 x 1/4	1
12	P23-00262	Nut - 6-32UNC x 1/4" Hex	2
13	F03-190FS	Nut - 10-32UNF - Hex	4
14	F06-190C04N	Screw - 10-24UNC x 1/4 Lg Skt Set	1
15	F10-138C08S	Screw - 6-32UNC x 1/2 Lg Skt Hd Cap	1
16	F10-138C12S	Screw - 6-32UNC x 3/4 Lg Skt Hd Cap	1
17	F10-164C06S	Screw - 8-32UNC x 3/8 Lg Skt Hd Cap	1
18	F10-190F06S	Screw - 10-32UNF x 3/8 Lg Skt Hd Cap	4
19	F10-250F06	Screw - 1/4-28UNF x 3/8 Lg Skt Hd Cap	1
20	F11-190F06S	Screw - 10-32UNF x 3/8 Lg Skt Btn Hd	2
21	F11-190C03S	Screw - 10-24UNC x 3/16 Lg Skt Btn Hd	1
22	F12-190F06S	Screw - 10-32UNF x 3/8 Lg Skt Flt Hd	4

APPENDIX



Kwik Lok[®] CORPORATION

EXECUTIVE OFFICE P.O. BOX 9548 YAKIMA, WA. 98909

TELEPHONE: 1-800-688-5945 or (509) 248-4770

FAX: (509) 457-6531

Internet: www.kwiklok.com

SUGGESTED SPARE PARTS INVENTORY FOR THE TYPE 086A MODEL 200P CLOSER

Part no.	Description	Qty.
0S-006	Spring (silver in color)	2
0S-012	Spring (gold in color)	2
0S-117	Spring	1
0S-118	Spring	2
0S-119	Spring	1
0S-120	Spring	1
P11-00270	Fuse - 115VAC	5
P11-00616	Fuse - 200 - 240VAC	5
P12-00085	Switch - Limit	1

NOTE: Specify on the order the TYPE, MODEL, and SERIAL NUMBER of the machine for which the parts are ordered. This information will be found on the machine's nameplate.

**CONTACT THE FACTORY FOR
CURRENT PRICES.**

Kwik Lok WARRANTY POLICY

Seller warrants that the equipment shall be free of defective workmanship or materials. Its obligation under this warranty to consist exclusively of repairing or replacing, free of charge f. o. b. its factory, any parts received at its factory within two years from the date of shipment of the respective equipment or parts alleged to be defective and determined by Seller upon inspection to be defective. No other warranty, expressed or implied, as to description, quality, merchantability, fitness for a particular purpose, or any other matter is given by Seller in connection with this sale. Under no circumstances shall Seller be liable for loss or profits or other consequential damages, or for any other direct or indirect costs, expenses, equipment or any part thereof. Neither shall the Seller be liable for any defects attributable to the use of any parts, supplies or service not manufactured, supplied or provided by the Seller.

Electric motors and controls carry a one year warranty in which motors or controls will be repaired and returned to the Buyer at no charge if the manufacturer determines the equipment to be defective in workmanship and / or materials.